

180 Deg BLDC Motor Driver for Optical Storage AM9858

The AM9858 is developed to drive Brush-less spindle motor. This IC has braking select. Forward rotation mode and braking mode are able to be selected by two control terminals.

● Applications

CD-ROM, DVD-ROM, DVD-RW , BD-ROM and car DVD drive

● Features

- | | |
|-------------------------------------|---|
| 1) Silent Direct-PWM-driving system | 5) Reverse rotation detect and protection |
| 2) Current limit circuit | 6) Low consumption |
| 3) Built in FG-output | 7) Short brake |
| 4) Hall Bias circuit | 8) Built-in thermal-shut-down circuit |

● Absolute Maximum Ratings (Ta = 25°C)

Parameter	Symbol	Limits	Unit
5V voltage Supply	Vcc1/Vcc2	7	V
Motor power supply	VM	15	V
Thermal Resistance Junction-ambient	θ_{ja}	*57	°C/W
Spindle output current	Io	*1.6	A
Power dissipation	Pd	*2.2	W
Operating temperature	Topr	-40 to +85	°C
Storage temperature	Tstg	**-40 to +150	°C

*Note : Absolute maximum ratings are those values beyond which the device could be permanently damaged. Absolute maximum ratings are stress ratings only and functional device operation is not implied.

*70mm×70mm×1.6mm glass epoxy board.

*Reducing in done at 17.6mW/°C for operating above Ta = 25°C.

**Do not exceed Pd ASO and Tj = 150°C.

● Recommended operating conditions

(Set the power supply voltage taking allowable dissipation into considering)

Parameter	Symbol	Min	Typ	Max	Unit
5V Power supply	Vcc1/Vcc2	4	5	6	V
Motor power supply	VM	VCC1/VCC2	12	14	V
Spindle output current	Io	-	1.0	1.5	A
PWM carrier frequency	Fosc	-	130	-	KHz

● **Electrical Characteristics**

(Unless otherwise specified, Ta = 25°C, VCC1=VCC2= 5V, VM=12V, RSP=0.44Ω, VREF=1.65V)

Parameter	Symbol	Limit			Unit	Conditions
		Min	Typ	Max		
Common						
Sleep current	I _{sc}	-	500	-	uA	MU1=0V
Quiescent current	I _{cc}	-	4	-	mA	MU1=5V, MU2=5V
MUTE1/MUTE2 terminal low voltage	VMU1L/ VMU2L	0	-	0.8	V	MU1/MU2
MUTE1/MUTE2 terminal high voltage	VMU1H/ VMU2H	2.5	-	5	V	MU1/MU2
MUTE1/MUTE2 terminal input current	IMU1/ IMU2	-	85	200	uA	MU1/MU2=5V
PWM carrier frequency	Fosc	-	130	-	KHz	OSC: with 68pF
VREF input voltage range	VinREF	1.0	-	3.0	V	
VREF terminal input current	IinREF	-	90	-	uA	VREF=1.65V
Spindle driver block < Hall bias>						
HB output voltage	VHB	0.8	1.1	1.4	V	IHB = 10mA
		2.1	2.5	2.8	V	IHB = 30mA
HB terminal sink current	IHB	-	-	30	mA	MU1=5V
Spindle driver block <Hall amplifier>						
Common mode input range	VHcom	1.3	-	3.7	V	HU+, HU-, HV+, HV-, HW+, HW-
Input signal level	VHmin	60	-	-	mVp-p	HU+, HU-, HV+, HV-, HW+, HW-
Spindle driver block <Torque control>						
Output on resistance	RDSON	-	2.0	-	Ω	I _o =0.5[A], VM=12V
Output on resistance	RDSON	-	3.0	-	Ω	I _o =0.25[A], VM=5V
Control voltage dead zone-	VDZ-	-80	-40	0	mV	SPIN<VREF [REVERSE]
Control voltage dead zone+	VDZ+	0	+40	+80	mV	VREF<SPIN [FORWARD]
Control gain	Gvo	0.85	1.0	1.15	V/V	G _{io} =G _{vo} /R _s [A/V]
Control limit 1F	Vlim1F	0.46	0.55	0.615	V	Ilim1F=Vlim1F/R _s [FORWARD] MU2=0V
Control limit 1R	Vlim1R	0.28	0.33	0.38	V	Ilim1R=Vlim1R/R _s [REVERSE]

- ◆ This product is not designed for protection against radioactive rays.
- ◆ Hall sensor power supply is recommended to be 5V to ensure Hall input range keeps 1.3V/min ~3.7V max at Ta= -40°C~85°C condition.

● Block Diagram

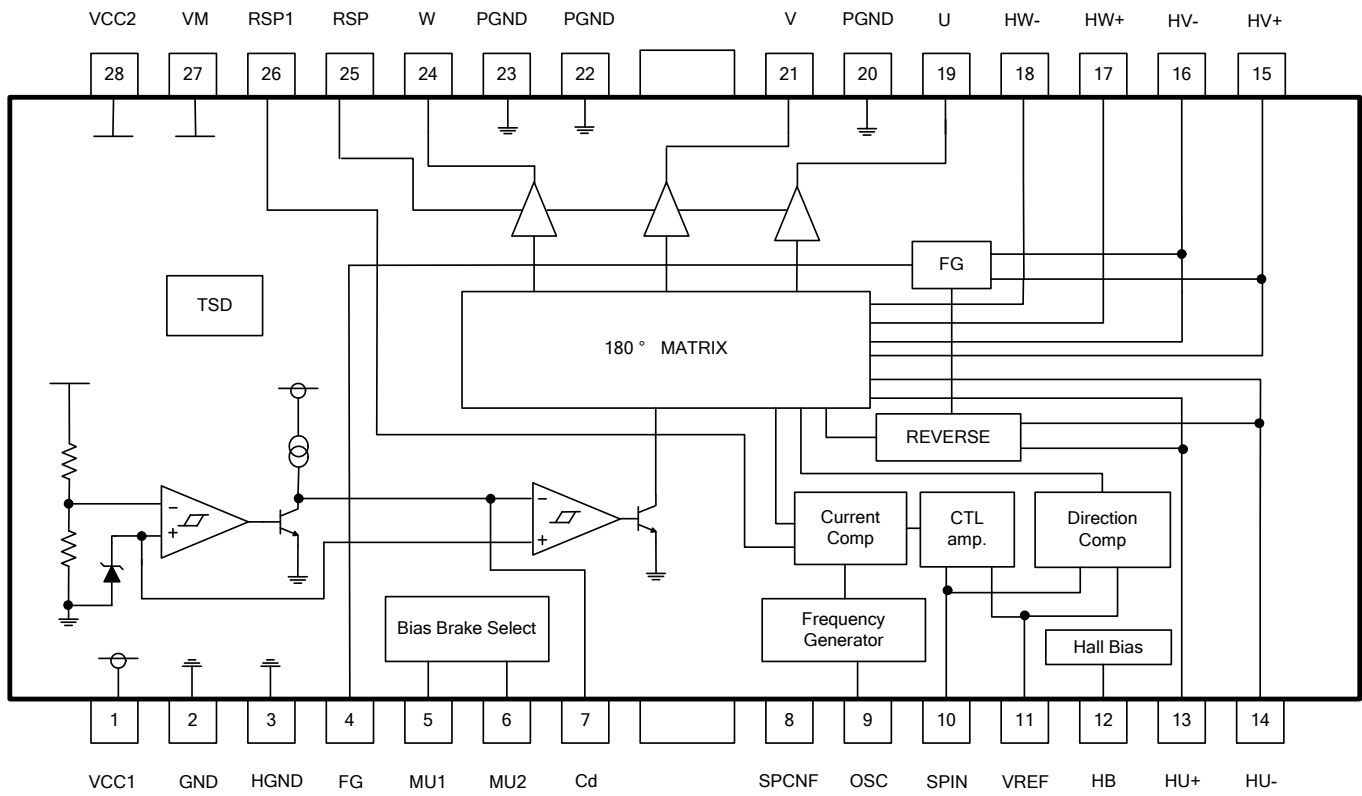

● Pin configuration

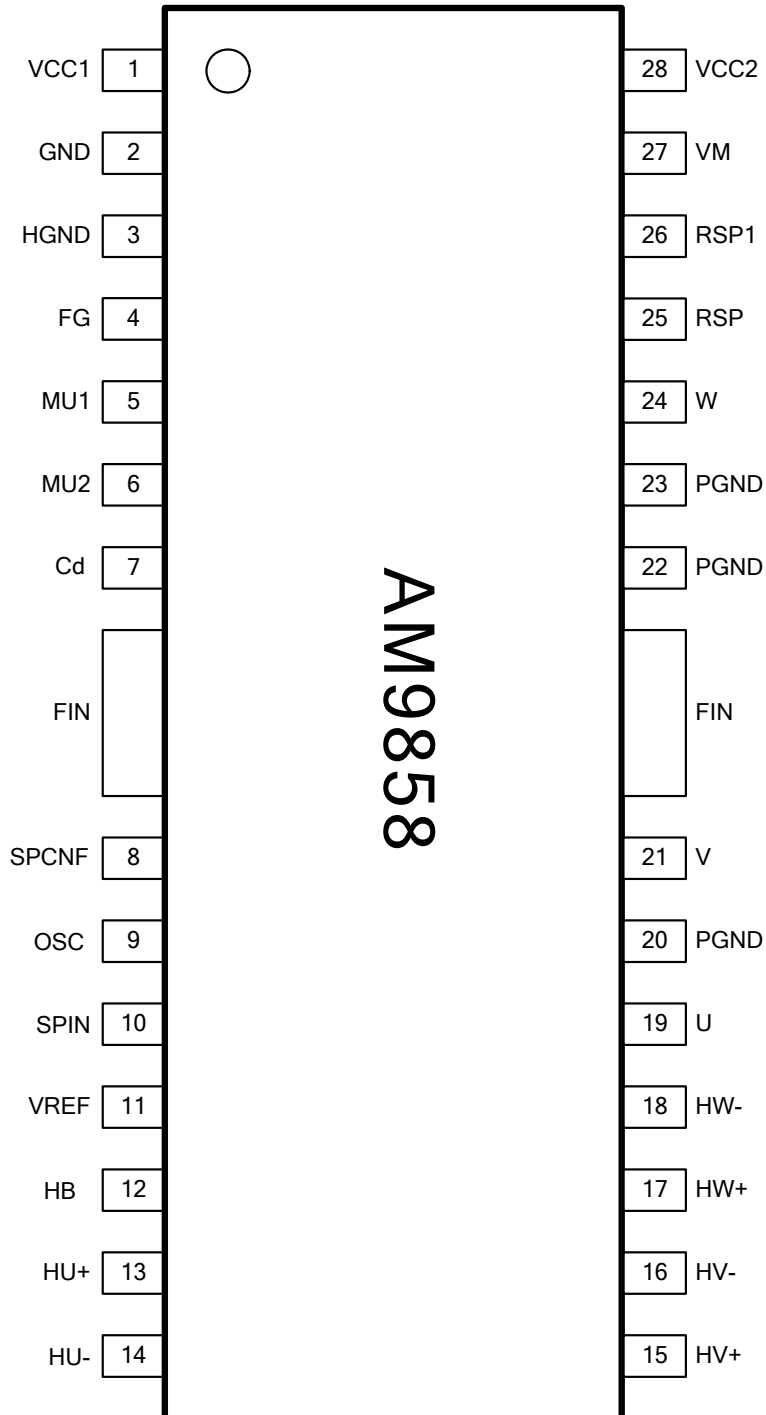

● **Pin Description**

PIN No	Pin Name	Function
1	VCC1	5V Power Supply
2	GND	GND
3	HGND	HGND
4	FG	Frequency generator output
5	MU1	Mute/Brake select terminal 1
6	MU2	Mute/Brake select terminal 2
7	Cd	Delay time capacitor pin
8	SPCNF	Spindle reference capacitor
9	OSC	PWM carrier oscillation set
10	SPIN	Spindle driver input
11	VREF	Reference voltage input
12	HB	Bias for Hall Sensor
13	HU+	HU+ sensor amp. Input
14	HU-	HU- sensor amp. Input
15	HV+	HV+ sensor amp. Input
16	HV-	HV- sensor amp. Input
17	HW+	HW+ sensor amp. Input
18	HW-	HW- sensor amp. Input
19	U	Motor drive output U
20	PGND	Power GND
21	V	Motor drive output V
22	PGND	Power GND
23	PGND	Power GND
24	W	Motor drive output W
25	RSP	Spindle current sense
26	RSP1	Spindle current sense1
27	VM	Motor Power Supply
28	VCC2	5V Power Supply

● Power dissipation curve:

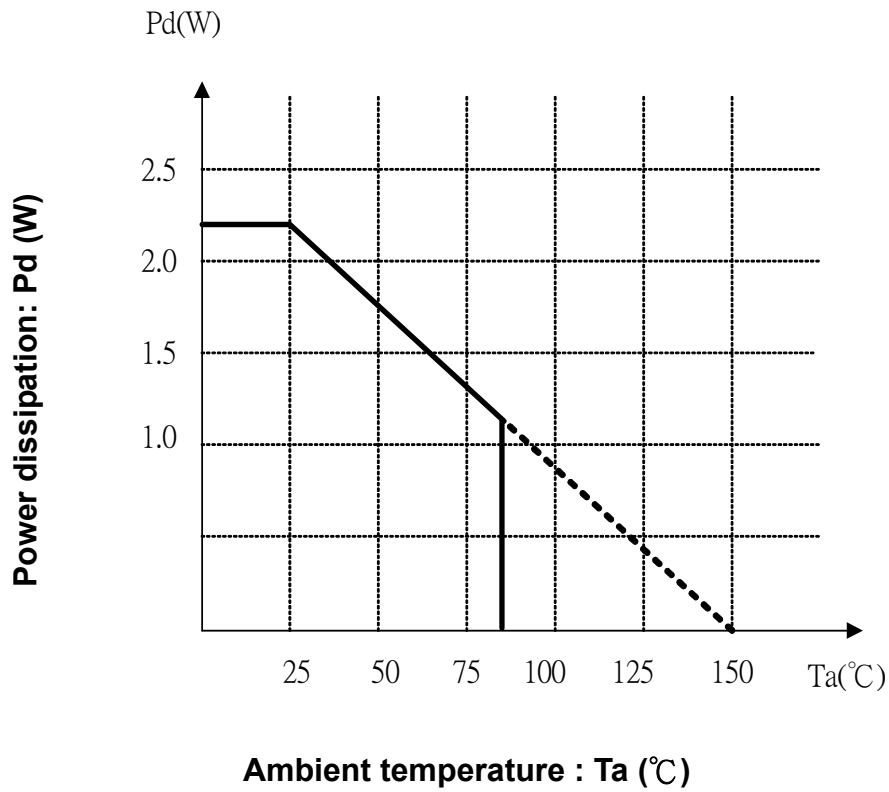

*70mm×70mm×1.6mm glass epoxy board.

*De-rating is done at 17.6mW/°C for operating above $T_a=25^\circ\text{C}$

● Application circuit (operate VM=12V)

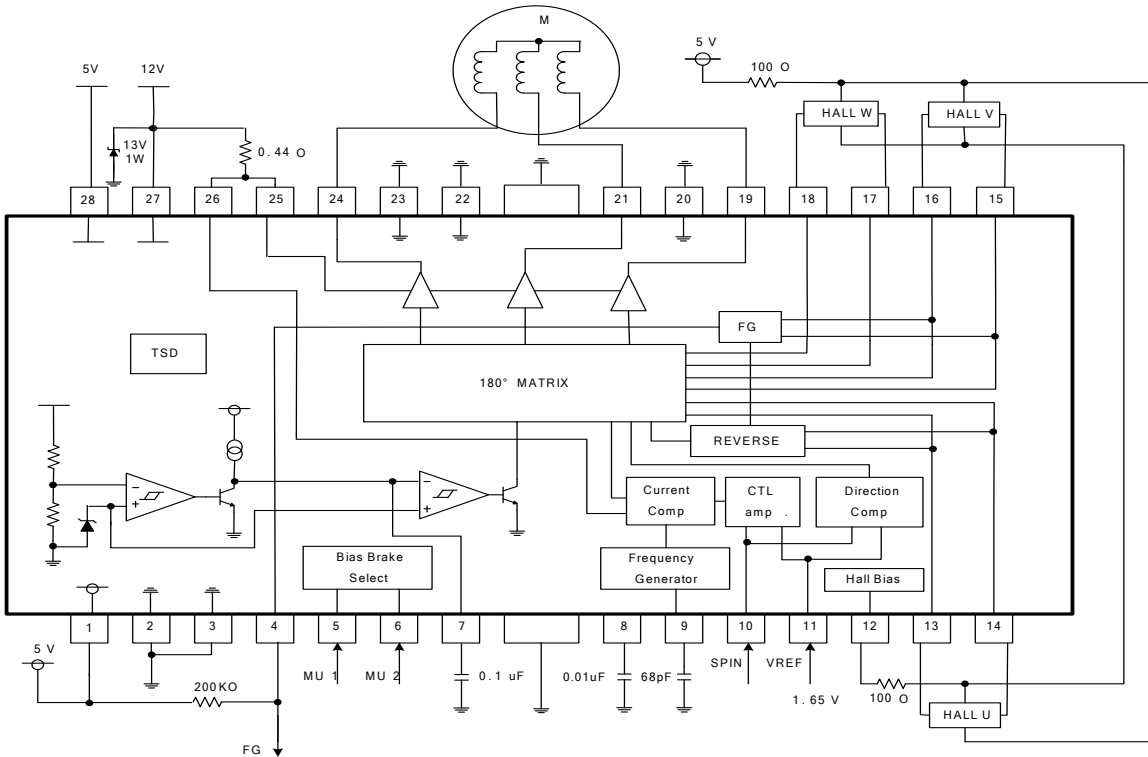

● Application circuit (operate VM=5V)

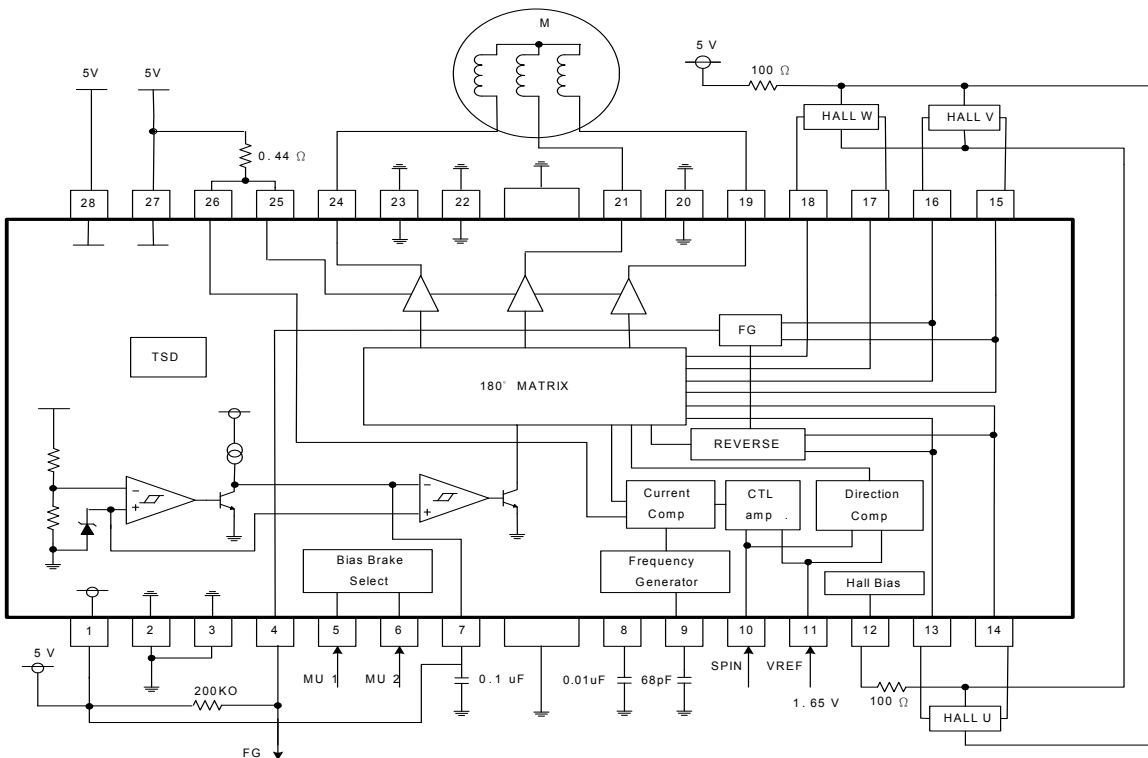

- ◆ Hall Vp-p input signal level is recommended to be at least 450mV to ensure sufficient UVW output driver current 1.9A p-p at VM= 8v, Rsp=0.44 ohm , Ta=85'c condition.

● I/O circuit

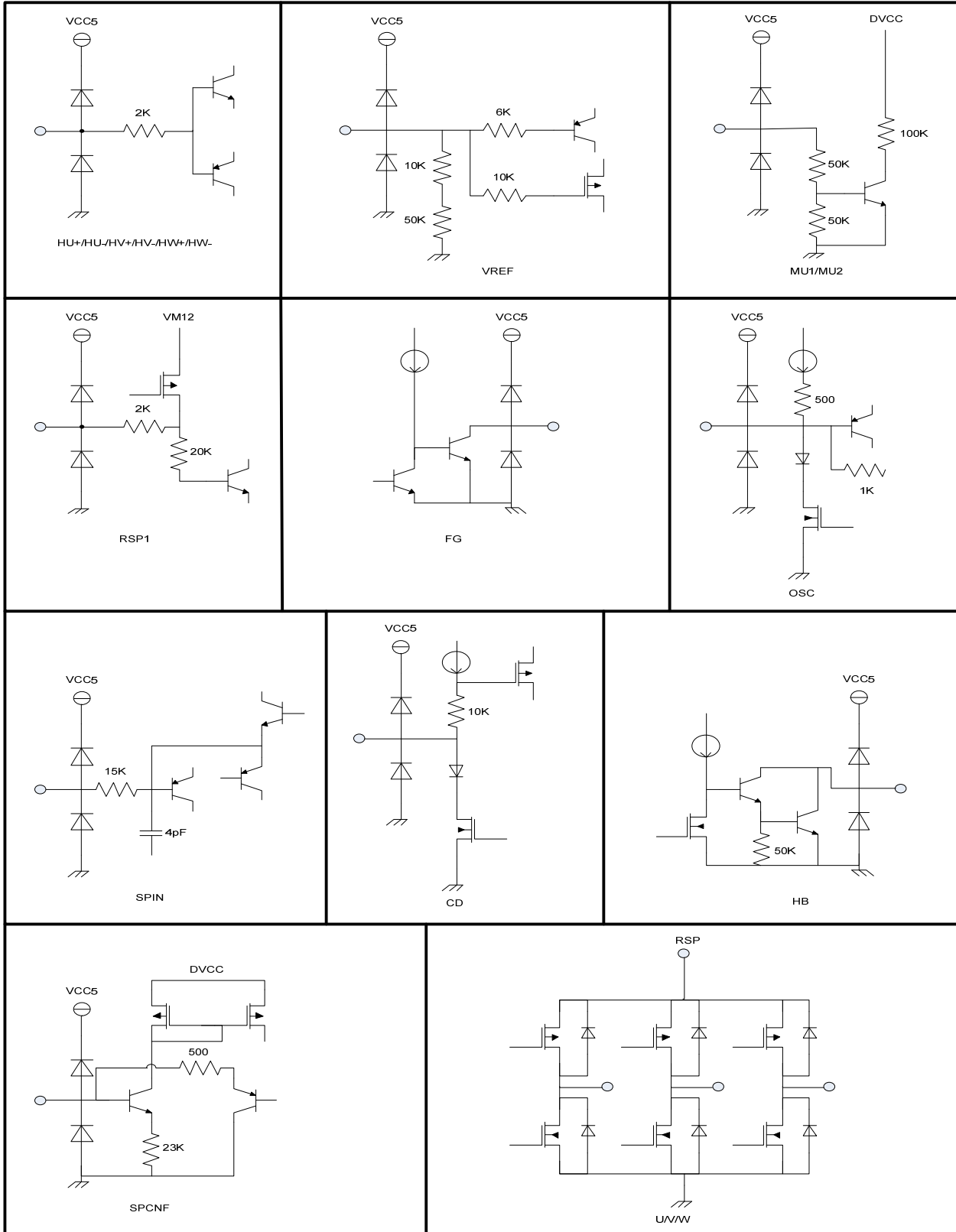

Input-Output timing chart

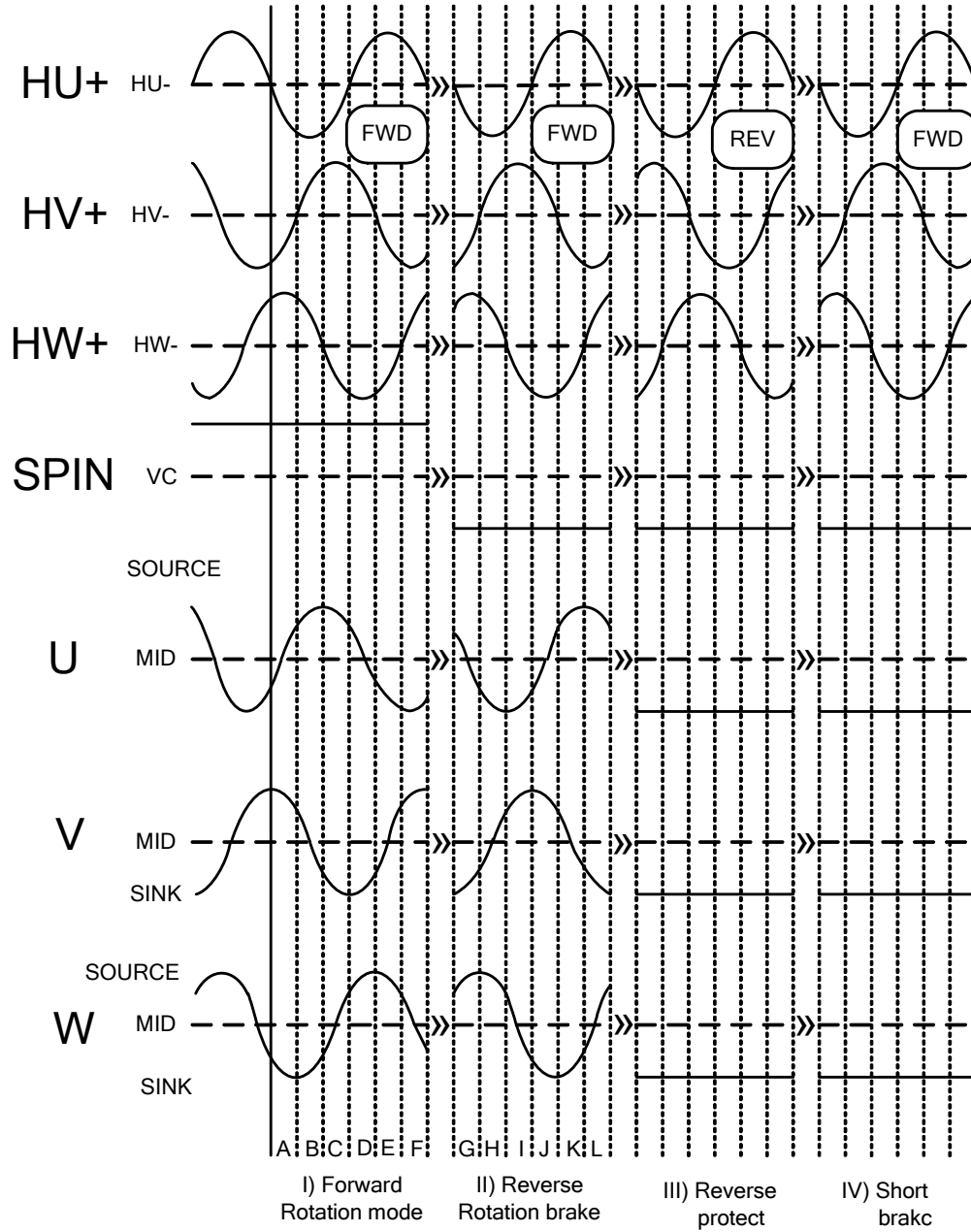

● **Function description**

1. The short brake is switched by MU1 and MU2 pin, the operation is shown in the table as below.

MU1 (pin5)	MU2 (pin6)	Spindle	VREF < SPIN	SPIN < VREF
L	L	X	--	--
L	H	X	--	--
H	L	O	Rotating forward	Short circuit brake ♦1
H	H	O	Rotating forward (58%)	PWM brake (58%) ♦2

♦1 Short-circuit braking mode

All the spindle driver outputs are shorted out to GND when SPIN < VREF.

♦2 PWM Reverse-rotation braking mode

A reverse-rotation torque is applied when SPIN < VREF. Reverse-rotation is detected with SPIN input and Hall input. If the spindle detects reverse rotation when SPIN < VREF, all the outputs are shorted out to GND.

2. Torque command (SPIN: pin 10)/ output current detection terminals (RSP: pin 25 and 26)

The relationship between the differential voltage between SPIN and VREF and the torque is shown in following Figure. The voltage gain [Gvo] is 0.55[V/V].

The current gain [Gio] is 1.0[A/V](at Rs=0.5Ω, and Rin=15KΩ) in forward torque directions, and the dead zone is from 0mV to 80mV (at Rin=0)

Current-gain-control and current-limit of this IC is determined with sensing resistor value, and more detail control can be determined with setting a gain-resister outer this IC as below.

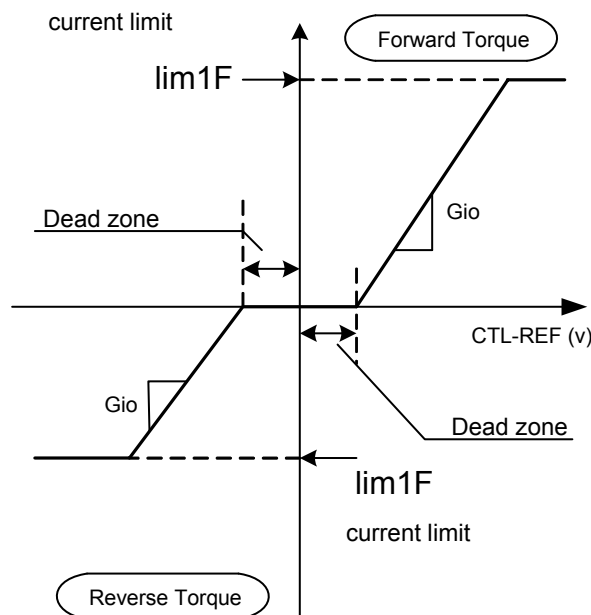

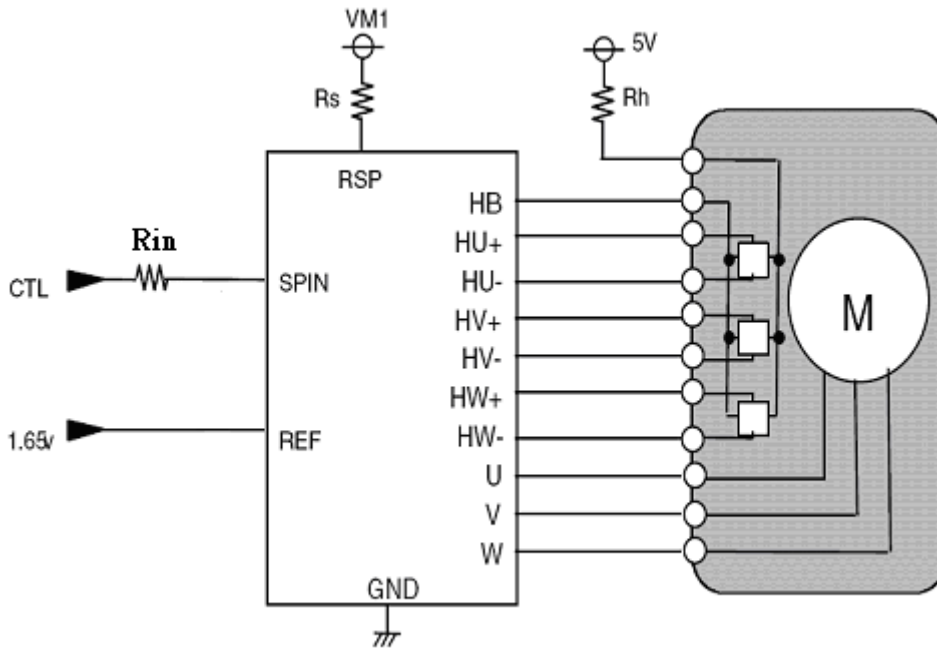

Table of gain formula

RS[Ω]	Ilim1F [A]	Ilim1R [A]	Gio=[A/V], Rin=15KΩ
0.50	1.1	0.64	1.00
0.75	0.73	0.43	0.67
1.00	0.55	0.32	0.5
Gio=15K/[RS*(Rin+15K)][A/V]			

3. PWM carrier frequency setting

PWM carrier frequency is decided by charging and discharging the capacitor that is connected to OSC Pin. The relationship with capacitors and frequency as below:

Capacitor (pF)	47	56	68	82	100	150	200
Carrier Frequency (KHz)	170	150	130	118	97	70	54

4. Voltage detection

1) Input voltage detection function

	IC status
$V_M < 6.6$	IC disable
$V_M > 7.4$	IC enable

2) Delay time capacitor

IC reset time can be set by the capacitance connected to the Cd pin.

$t_{PLH} = 174000 * C$ [t_{PLH} : transmission delay time(s), C: capacitor value(F)].

3) Timing chart

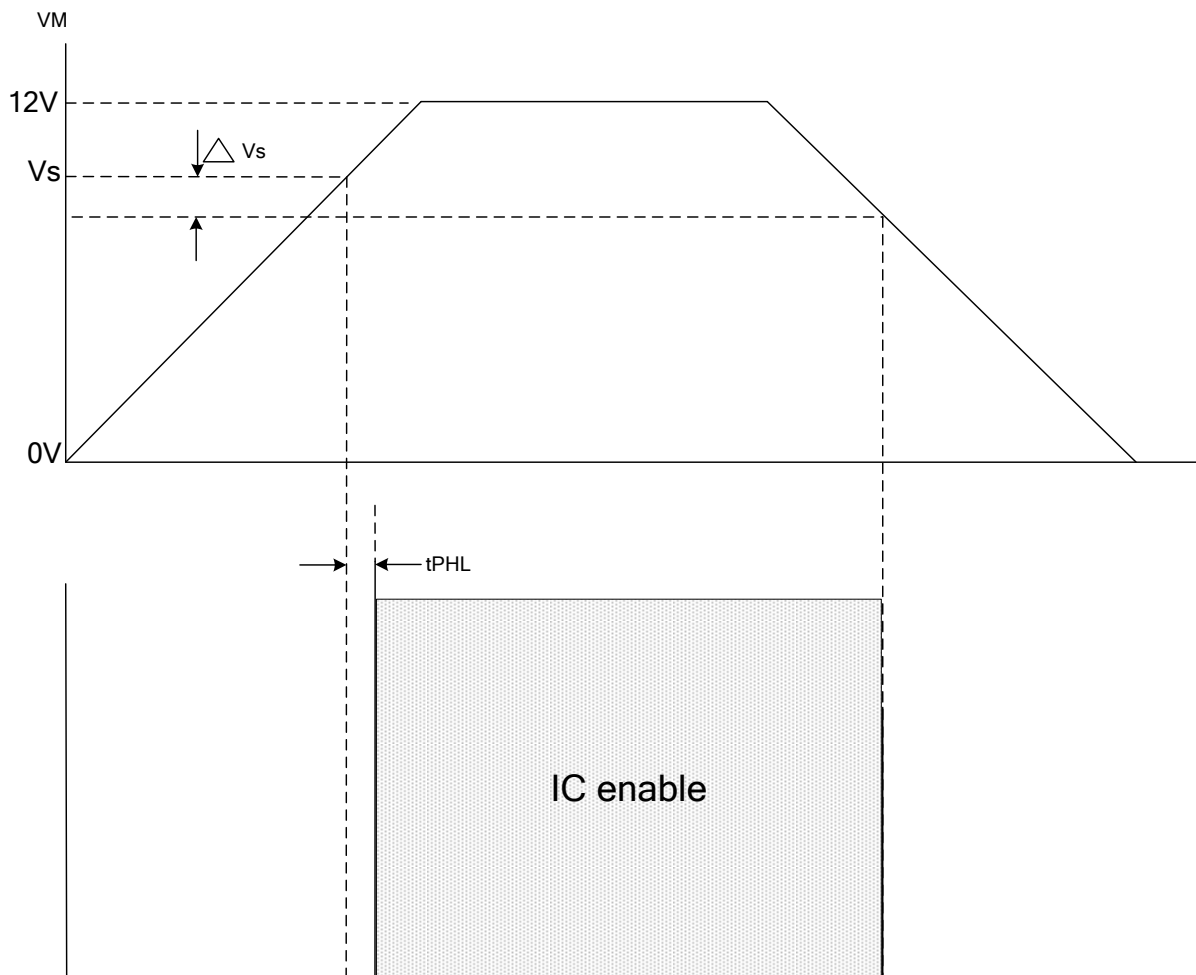

● Notice

1) Wiring for RSP

Considering the wiring resistance, connect each detecting resistor as close as possible to the current detection terminals for the spindle drive RSP (pin 25, 26) of the IC.

2) Reverse-rotation braking

In the case of reverse-rotation braking from high speed rotation, pay good attention to reverse electromotive force. Furthermore, fully check the voltage to be applied to the output terminal and consider the revolutions applied to the reverse-rotation brake.

3) Bypass capacitor

Please connect a bypass capacitor (0.1uF) across the supply voltage lines close to the IC pins.

Supply fault, ground fault, and short-circuit between output terminals.

Do not short-circuit between any output pin and supply pin (supply fault) or ground (ground fault), or between any output pins (load short-circuit). When mounting the IC on the circuit board, be extremely cautious about the orientation of the IC. If the orientation is mistaken, the IC may break down, and produce smoke in some cases.

4) Heat dissipation fins

Heat dissipation fins are attached to the GND on the inside of the package. Make sure to connect them to the external GND.

5) Brake mode select

This IC has two brake mode, PWM Reverse-rotation braking mode and Short-circuit braking mode.

It is possible to select brake mode when MU2(pin6) terminal are set "H" or "L".

In this IC recommendation, Short-circuit braking mode is superior to PWM Reverse-rotation braking to reducing the power dissipation and to avoid breaking down of this IC.

We suggest to take Short-circuit braking mode over 3000rpm and PWM Reverse-rotation braking mode below 3000rpm.

6) MU1 H→L setting

Before MU1(pin5) terminal set are from "H" to "L", please low down pin10(SPIN) voltage to ensure the spindle motor speed lower than 3000RPM.

7) The capacitor between RSP-GND

The capacitor between RSP-GND absorbs change of steep voltage and current on account PWM drive, and suppresses disorder of VM voltage. However, if a capacitor becomes far from IC, the effect will fall under the influence of wiring impedance etc. Please arrange the capacitor between RSP-GND near the IC.

● **Condition of Soldering**

1).Manual Soldering

Pb-free: Time / Temperature \leq 3 sec / $400 \pm 10^\circ\text{C}$ (2 Times)

Test Results : 0 fail/ 22 tested

Manual Soldering count : 2 Times

2).Re-flow Soldering (follow IPC/JEDEC J-STD-020D)

Classification Reflow Profile

Profile Feature	Pb-Free Assembly
Average ramp-up rate (T_L to T_P)	3°C/second max.
Preheat	
- Temperature Min (T_s min)	150°C
- Temperature Max (T_s max)	200°C
- Time (min to max) (t_s)	60-180 seconds
T_s max to T_L	
- Temperature Min (T_s min)	3°C/second max.
Time maintained above:	
- Temperature (T_L)	217°C
- Time (t_L)	60-150 seconds
Peak Temperature (T_P)	260 +0/-5°C
Time with 5°C of actual Peak	20-40 seconds
- Temperature (t_p)	
Ramp-down Rate	6°C/second max.
Time 25°C to Peak Temperature	8 minutes max.

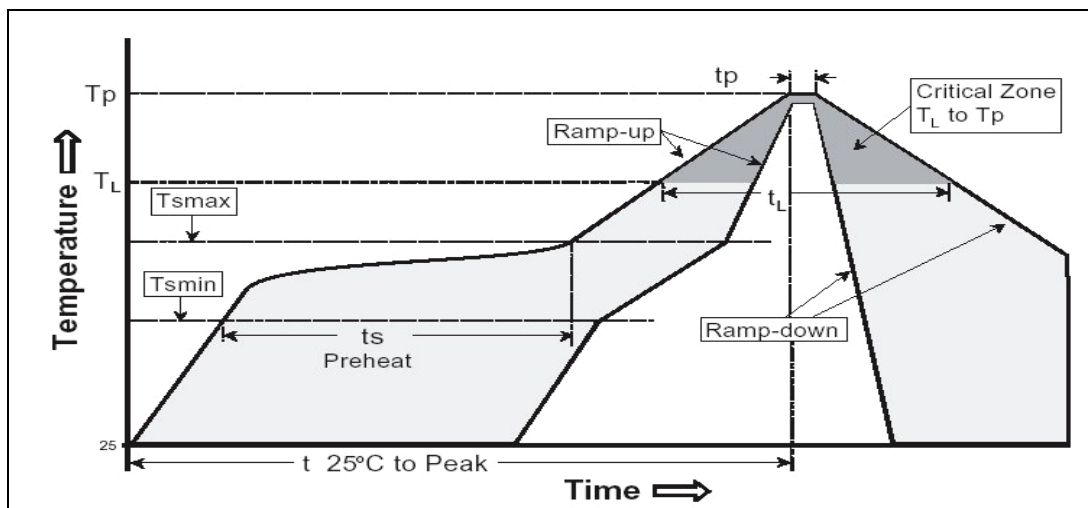

- Test Results : 0 fail/ 32 tested
- Reflow count : 3 cycles

● Packaging outline

HSOP28

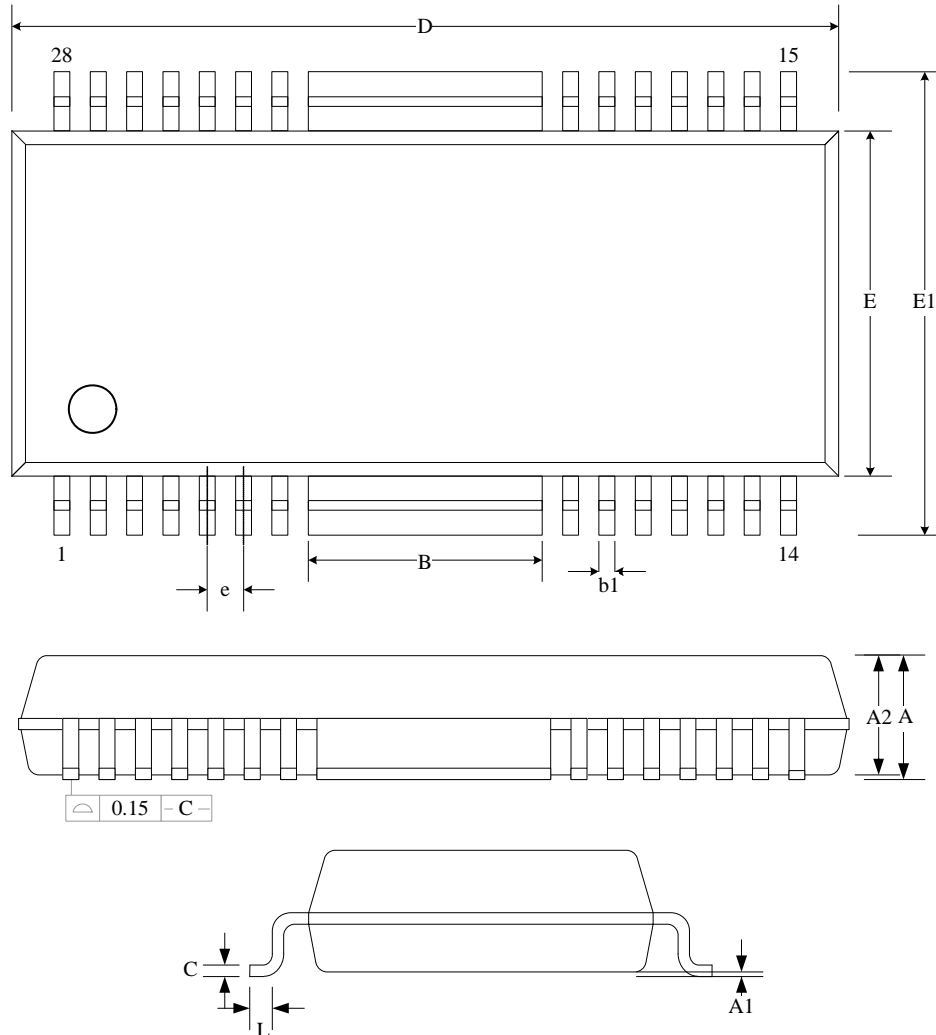

SYMBOL	MILLIMETERS		INCHES	
	Min.	Max.	Min.	Max.
A	2.35	2.75	0.0959	0.108
A1	-	0.3	-	0.012
A2	-	2.55	-	0.096
B	4.95	5.35	0.195	0.211
b1	0.23	0.47	0.009	0.019
C	0.2	0.36	0.008	0.014
D	17.89	18.8	0.704	0.740
E	7.3	7.9	0.287	0.311
E1	9.6	10.65	0.378	0.419
e	0.8 (TYP)		0.031(TYP)	
L	0.3	1.27	0.012	0.05

● **Marking Identification**

