

One Channel H-Bridge Motor Driver AM2878

● Features and Benefits

- 1) Lowest $R_{DS(on)}$ 115m Ω for high efficient H-Bridge output
- 2) SOP-8 package for small size PCB layout
- 3) Maximum continuous current output 3A
- 4) Operation voltage range 4V to 33V
- 5) Absolute maximum voltage 42V
- 6) Over temperature protection
- 7) Over current protection
- 8) Low standby current
- 9) Low quiescent current

● Application

- Robotic
- AI Home Appliances
- DC Brushed Motor Drive
- Industrial Equipment
- Other Mechatronic Applications
- Servo Motor

● Description

The AM2878 output driver block consists of N-channel and P-channel power MOSFETs configured as an H-Bridge to drive DC motor.

AM2878 maximum operational voltage is 33V. It can supply up to 3A of continuous current and 5A of peak current. There are internal shutdown functions, thermal shutdown protection and overcurrent protection ($I_{OCP} = 5\text{ A}$).

Package material is Pb-Free Product & RoHS compliant for the purpose of environmental protection and for sustainable development of the Earth.

● Ordering Information

Orderable Part Number	Package	Marking
AM2878	SOP-8	AM2878

● **Absolute Maximum Ratings ($T_A=25^{\circ}\text{C}$)**

Parameter	Symbol	Limits	Unit
Power Supply Voltage	VCC	42	V
Output Continuous Current	$I_{O\text{ CONT}}$	3.0 (NOTE*)	A
Output Peak Current	$I_{O\text{ peak}}$	5	A
Operate Temperature Range	T_{opr}	-20~+85	$^{\circ}\text{C}$
Storage Temperature Range	T_{stg}	-40~+150	$^{\circ}\text{C}$

Note *: Based on $25 \times 25 \text{mm}^2$ FR4 PCB (1 oz.) at single side PCB

● **Recommended Operating Conditions ($T_A = 25^{\circ}\text{C}$)**

(Set the power supply voltage taking allowable dissipation into considering)

Parameter	Symbol	Min.	Typ.	Max.	Unit
Power Supply Voltage	VCC	4		33	V
Signal Input IN_A and IN_B Voltage	V_{IN_X}	-0.3		6*	V
H-Bridge Output Continuous Current	I_{OUT}	0		3.0(Note**)	A
Externally Applied PWM Frequency	F_{IN_X}			30	KHz

Note*: Input signal voltage is not higher VCC voltage.

Note**: Based on $25 \times 25 \text{mm}^2$ FR4 PCB (1 oz.) at single side PCB

● Electrical Characteristics (Unless otherwise specified, TA = 25°C, VCC=6V)

Parameter	Symbol	Limit			Unit	Conditions
		Min.	Typ.	Max.		
Power Supplies						
Supply Current	I _{CC}		4		mA	Input signal IN_A/B= L/H or H/L or H/H No load on OUT_A/B,
Standby Current	I _{STB}			2	uA	Input signal IN_A/B= L/L
IN_X Inputs						
Input H level Voltage	V _{IN_XH}	2.0		6	V	
Input L level Voltage	V _{IN_XL}	-0.3		0.7	V	
Input H level Current	I _{IN_X}		100		μA	V _{CC} = 6V, V _{IN} = 3V
Input Frequency	F _{IN_X}			30	KHz	
Input Pull Down Resistance	R _{IN_X}		30		KΩ	
H-bridge FETs						
On-Resistance	R _{ds(on)}		115		mΩ	I _O = 1A Upper and Lower total
On-Resistance	R _{ds(on)}		130		mΩ	I _O = 3A Upper and Lower total
TSD Protections						
Thermal Shutdown Protection	TSD _P		160		°C	
Thermal Shutdown Release	TSD _R		105		°C	

● Block Diagram

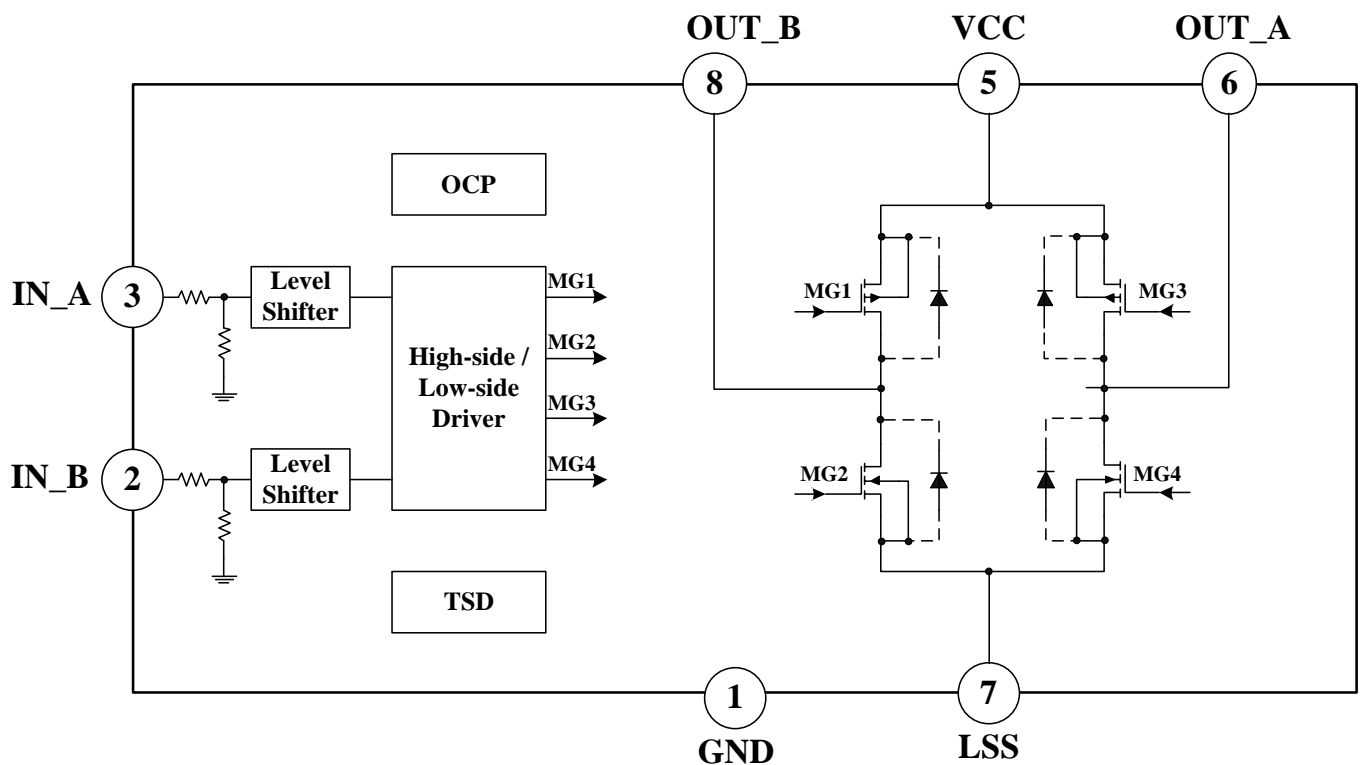

● Input Logic Descriptions

Function Truth Table

IN_A	IN_B	OUT_A	OUT_B	Mode
L	L	Hi-Z	Hi-Z	Stop
L	H	L	H	Reverse
H	L	H	L	Forward
H	H	L	L	Brake

● Pin configuration SOP-8

Top View

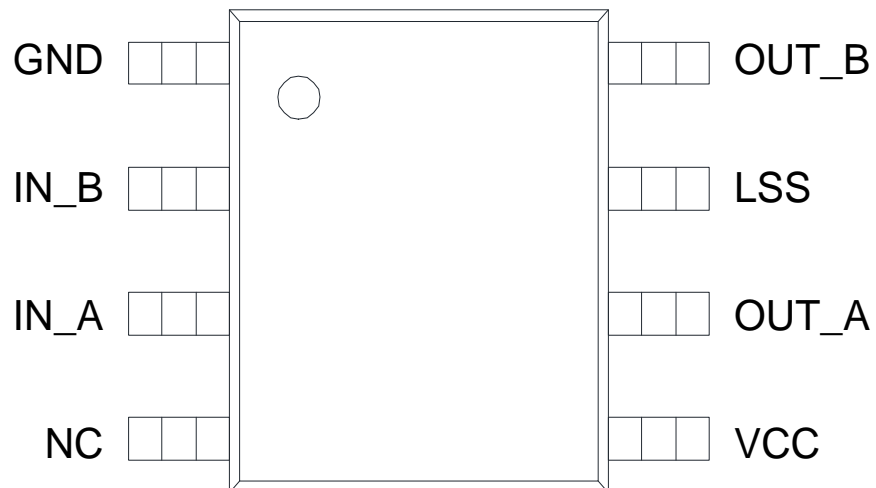

● Pin Descriptions

PIN No.	Pin Name	I/O	Description
1	GND	I	Ground Pin
2	IN_B	I	Input Half Bridge B
3	IN_A	I	Input Half Bridge A
4	NC	-	NC
5	VCC	I	Power Supply
6	OUT_A	O	Output Half Bridge A
7	LSS	-	Power Return – Sense Resistor Connection
8	OUT_B	O	Output Half Bridge B

● **Application:**

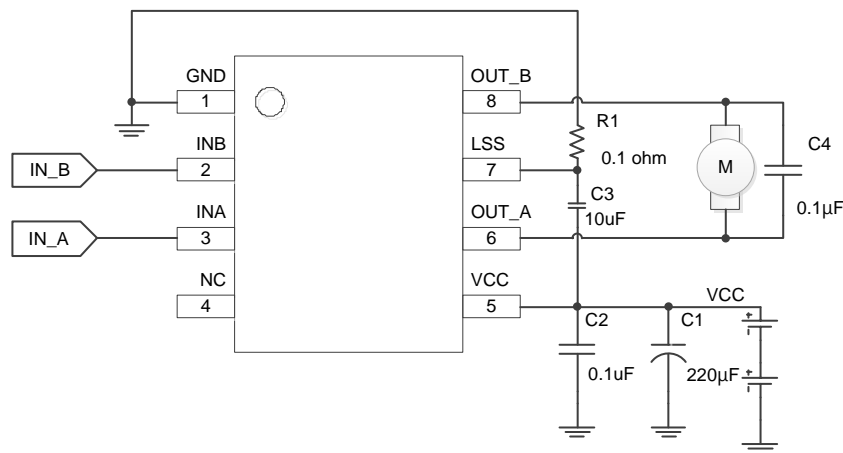

● **Circuit Descriptions**

1. C1 、 C2: Power supply VCC pin capacitor:
 - a. The capacitor can reduce the power spike when the motor is in motion. To avoid the IC directly damaged by the VCC peak voltage. It also can stabilize the power supply voltage and reduce its ripples.
 - b. The C1 capacitor can compensate power when motor starts running.
 - c. The capacitor value (uF) determines the stability of the VCC during motor in motion. If the large voltage power or a heavy loading motor is used, then a larger capacitor would be needed.
 - d. On the PCB configuration, the C1 、 C2 must be mounted as close as possible to VCC pin .

2. C4: The across-motor capacitor
 - a. The C4 capacitors can reduce the power spike when motor is running. 0.1uF capacitor is recommended.
 - b. The C4 capacitor must be added to the general application.

3. If C1 layout location is away from VCC power line or R1 resistor value is larger than 100mΩ, the C3 capacitors 10uF or is highly recommended to be placed in parallel with AM2878 VCC to LSS; the capacitor layout location should be placed as close as practicable to AM2878. Please refer to above application circuit diagram, it is to suppress sampling resistor R1 ground noise to ensure MCU ADC detect sampling voltage precisely.

4. It's not allowed INA, INB input remain floating status, because there is a minor leakage current between P-N junction when temperature rising, the leakage current will go through internal pull- low resistor which causes INA or INB floating level abnormal pull high and output abnormal working.

5. Sense Pin (LSS): When current sense (sampling resistor) is used, to feedback sampling voltage to MCU precisely, please refer to following suggestion to get optimal performance:

In order to use PWM current control, a low-value resistor (R1) less than 100mΩ is placed between the LSS pin and ground for current sensing purposes. The ground-trace should be as short as possible. For low-value sense resistors, the ground-trace voltage drops in the PCB can be significant, and should be taken into account.

When selecting a value for the sense resistor be sure not to exceed the maximum voltage on the LSS pin of ±250 mV at maximum load. During over-current events, this rating may be exceeded for short durations.

6. There are many type of motors which cause different level of power spike and ground switching noise, please follow above application recommendation, if there is any questions, please feel free to contact us.

● Layout Guidelines

1. Layout Example

PCB Size 25x25 mm² 、single side

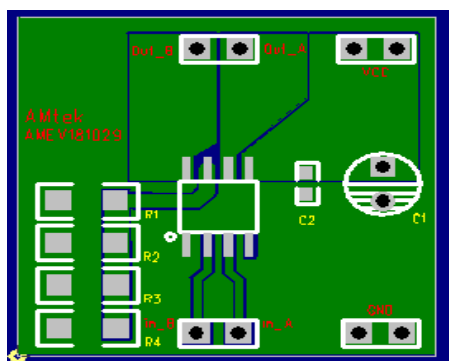

Top Layer

2. Layout Consideration

The layout is very important when designing high current and high frequency switching converters. Layout will affect noise pickup. Correctly layout can realize a good design with less background noise.

Make all the connections for the power components in the top layer with wide, copper filled areas or polygons. In general, it is desirable to make proper use of GND planes and polygons for power distribution and heat dissipation.

3. Power trace

- 3.1 Power trace (VCC) should be as short as possible.

- 3.2 On the PCB configuration, the C1 and C2 must be mounted as close as possible to VCC pin, in order to reduce EMI noise.

- 3.3 To ensure that power trace can conduct 3A current, the width of power trace should be wider than 2 mm.

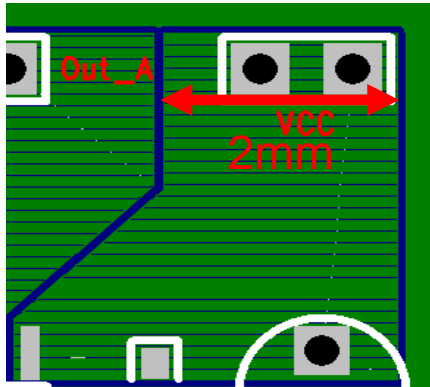

4. OUTPUT

4.1 OUT_A and OUT_B trace width need at least 2mm for 3A current going through.

4.2 For OUT_A & OUT_B thermal design consideration, it should be big one piece of copper (for example: 10.8mm x 5.1mm) without any gaps.

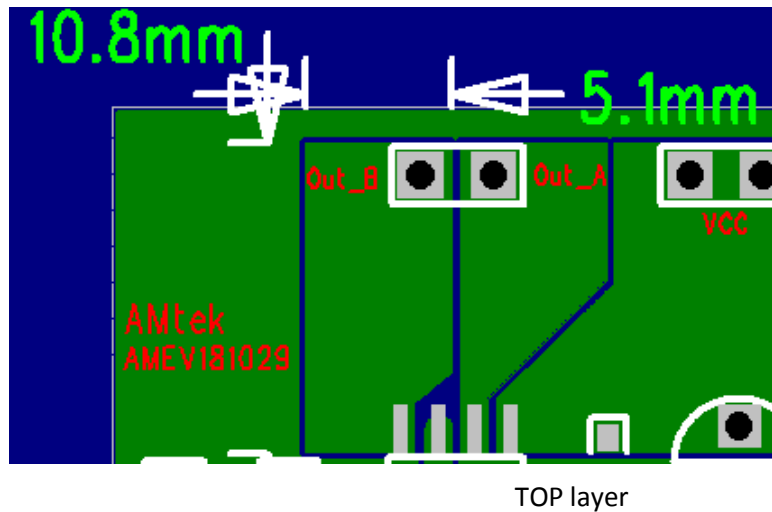

5. LSS

5.1 LSS is high-current path through the motor driver. The width of connecting metal trace should be as wide as possible.

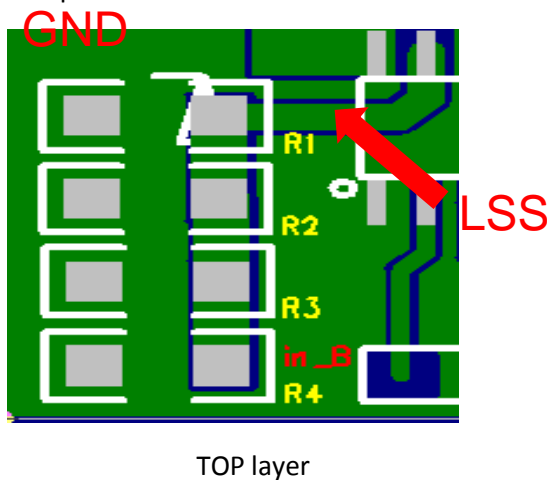

● Operating Mode Descriptions

H-Bridge basic operating mode :

a) Forward mode

Definition : When $IN_A=H$, $IN_B=L$, then $OUT_A=H$, $OUT_B=L$

b) Reverse mode

Definition : When $IN_A=L$, $IN_B=H$, then $OUT_A=L$, $OUT_B=H$

c) Brake mode

Definition : When $IN_A=IN_B= H$, then $OUT_A=OUT_B=L$

d) Stop mode

Definition : When $IN_A=IN_B= L$, then $OUT_A=OUT_B=Hi-Z$

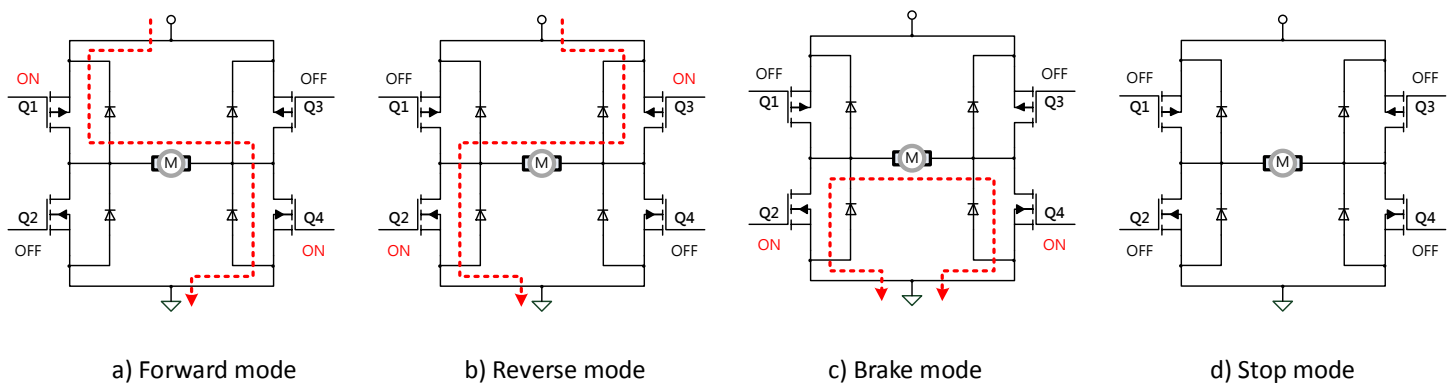

● Protection Mechanisms Descriptions

1) Over-current protection (OCP)

When the IC conducts a large current, 5A (Typ), the internal over-current protection function will be triggered. The device enter protection mode of auto-recover to avoid damaging IC and system.

2) Over-temperature protection

If the IC junction temperature exceeds 160 ° C (Typ.), the internal over-temperature protection function will be triggered, partial FETs in the H-bridge are disabled, that will ensure the safety of customers' products. If the IC junction temperature falls to 105 ° C(Typ.), the IC resumes automatically.

● **Thermal Information**

Θja	junction-to-ambient thermal resistance	89.2°C/W
Ψjt	junction-to-top characterization parameter	10.6°C/W

- **Θja** is obtained in a simulation on a JEDEC-standard 2s2p board as specified in JESD-51.
- The **Θja** number listed above gives an estimate of how much temperature rise is expected if the device was mounted on a standard JEDEC board.
- When mounted on the actual PCB, the **Θja** value of JEDEC board is totally different than the **Θja** value of actual PCB.
- **Ψjt** is extracted from the simulation data to obtain **Θja** using a procedure described in JESD-51, which estimates the junction temperature of a device in an actual PCB.
- The thermal characterization parameter, **Ψjt**, is proportional to the temperature difference between the top of the package and the junction temperature. Hence, it is useful value for an engineer verifying device temperature in an actual PCB environment as described in JEDEC JESD-51-12.
- When Greek letters are not available, **Ψjt** is written Psi-jt.
- Definition:

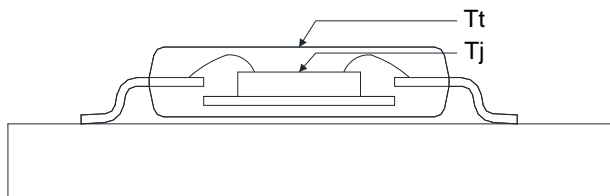

$$\text{定義} : \Psi_{jt} = (T_j - T_t) / P_d$$

Where :

Ψjt (Psi-jt) = Junction-to-Top(of the package) °C/W

Tj = Die Junction Temp. °C

Tt = Top of package Temp at center. °C

Pd = Power dissipation. Watts

- Practically, most of the device heat goes into the PCB, there is a very low heat flow through top of the package, So the temperature difference between **Tj** and **Tt** shall be small, that is any error caused by PCB variation is small.
- This constant represents that **Ψjt** is completely PCB independent and could be used to predict the **Tj** in the environment of the actual PCB if **Tt** is measured properly.

● **How to predict Tj in the environment of the actual PCB**

Step 1 : Used the simulated Ψ_{jt} value listed above.

Step 2 : Measure Tt value by using

➤ **Thermocouple Method**

We recommend use of a small ~40 gauge(3.15mil diameter) thermocouple. The bead and thermocouples wires should touch the top of the package and be covered with a minimal amount of thermally conductive epoxy. The wires should be heat-insulated to prevent cooling of the bead due to heat loss into wires. This is important towards preventing “too cool” Tt measurements, which would lead to the calculated Tj also being too cool.

➤ **IR Spot Method**

An IR Spot method should be utilized only when using a tool with a small enough spot area to acquire the true top center “hot spot”.

Many so-called “small spot size” tools still have a measurement area of 0~100+mils at “zero” distance of the tool from the surface. This spot area is too big for many smaller packages and likely would result in cooler readings than the small thermocouple method. Consequently, to match between spot area and package surface size is important while measuring Tt with IR sport method.

Step 3 : calculating power dissipation by

$$P \cong (VCC - |Vo_{Hi} - Vo_{Lo}|) \times I_{out} + VCC \times I_{cc}$$

Step 4 : Estimate Tj value by

$$T_j = \Psi_{jt} \times P + T_t$$

Step 5: Calculated Θ_{ja} value of actual PCB by the known Tj

$$\Theta_{ja}(\text{actual}) = (T_j - T_a) / P$$

● Maximum Power Dissipation (de-rating curve) under JEDEC PCB & actual PCB

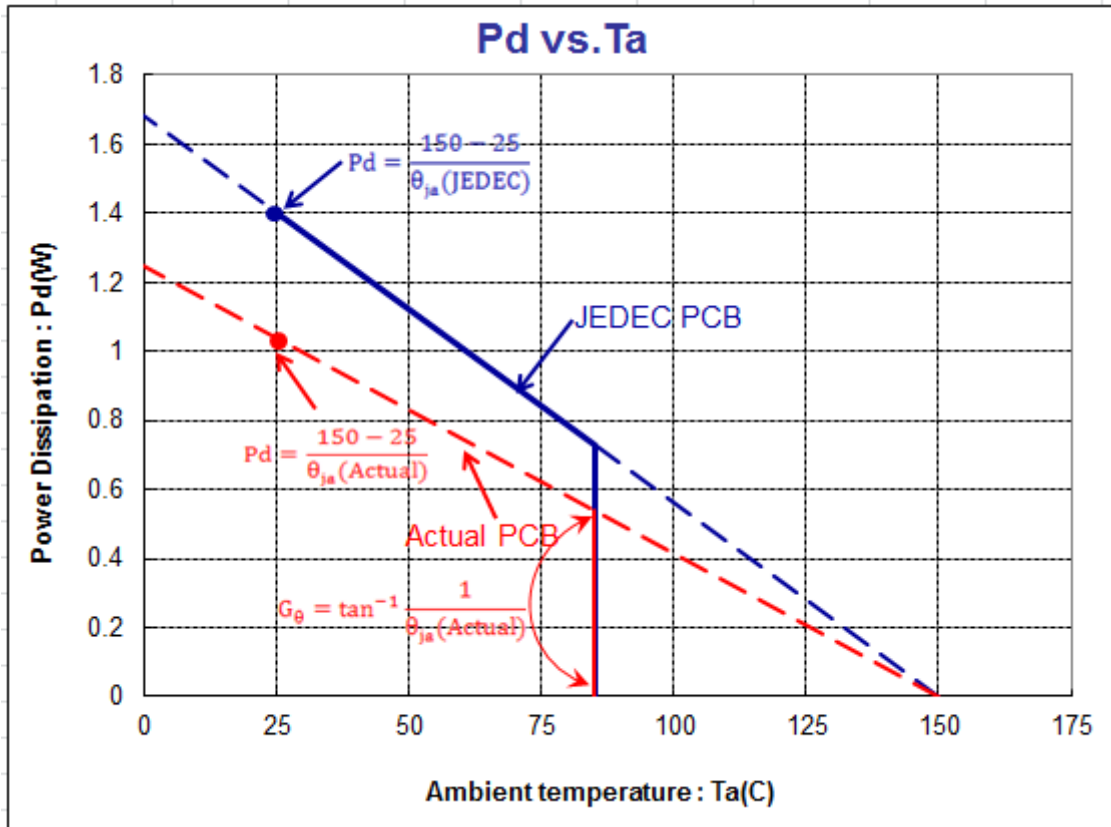

● Packaging outline --- SOP-8

Unit : mm

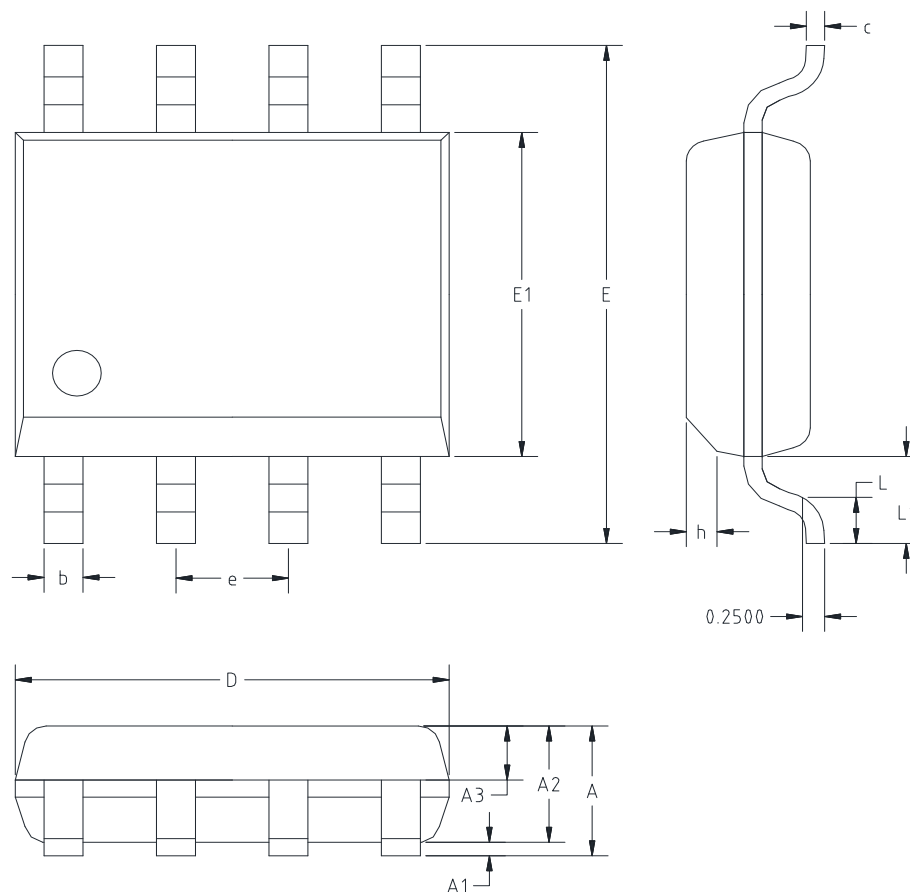

SYMBOL	MILLIMETERS		INCHES	
	Min.	Max.	Min.	Max.
A	--	1.75	--	0.069
A1	0.10	0.225	0.004	0.009
A2	1.30	1.50	0.051	0.059
A3	0.60	0.70	0.024	0.028
b	0.39	0.48	0.015	0.019
c	0.21	0.26	0.008	0.010
D	4.70	5.10	0.185	0.201
E	5.80	6.20	0.228	0.244
E1	3.70	4.10	0.146	0.161
e	1.27 TYP.		0.05 TYP.	
h	0.25	0.50	0.010	0.020
L	0.50	0.80	0.020	0.031
L1	1.05 TYP		0.041 TYP.	

● Marking Identification

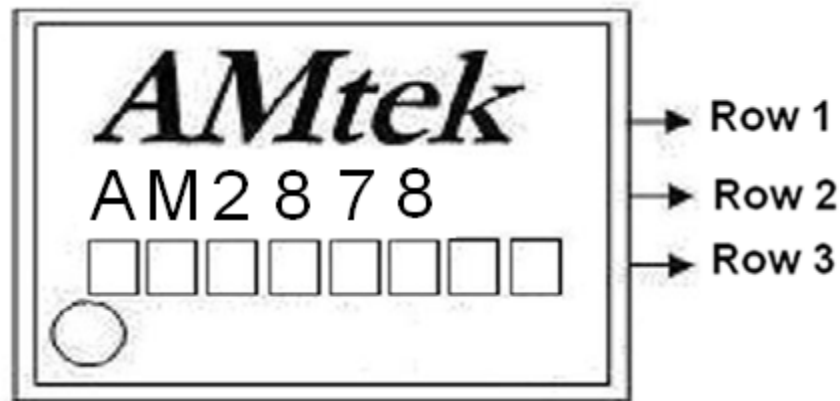

NOTE:

- Row1 : Logo
- Row2 : Device Name
- Row3 : Wafer Lot No use five codes + Assembly Year use one code + Assembly Week use two codes

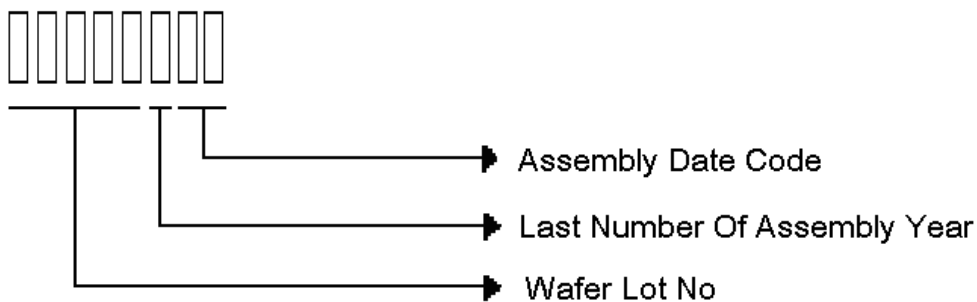

Example: Wafer Lot No is EB168 + Year 2017 is H + Week 08 is 08 , then mark "EB168H08"

The last code of assembly year, explanation as below: :

(Year : A=0,B=1,C=2,D=3,E=4,F=5,G=6,H=7,I=8,J=9. For example: year 2017=H)