

One Channel H-Bridge Power Driver AM1107

● Features and Benefits

- Wide supply voltage range up to 11V
- Maximum continuous current output up to 1.3A
- Low $R_{DS(ON)}$ for high efficient H-bridge output.
- Built-in LDO Regulator 2.76V
- LDO output driver current 100mA
- SOP-8 package for small size PCB layout
- Over current protection
- Over temperature protection
- Low standby current
- Low quiescent current

● Application

- Robotics (R/C servo, Sweeping robot)
- Toys (R/C car, R/C aircraft)
- Small Appliances (Reduce PCB surface area and perimeter)
- Any relevant DC motor applications.

● Description

The AM1107 is a channel H-Bridge driver with a built in Low Dropout Regulator (LDO). It provides integrated motor-driver solution for high current power motion control applications. The output driver block consists of N-channel and P-channel power MOSFETs configured as H-Bridge to driver DC motor.

The AM1107 maximum operational voltage is 11V. It can supply up to 1.3A of output continuous current and 2.5A of output peak current. There are internal shutdown function for over-temperature protection and over-current protection ($I_{OCP} = 2.5 A$).

Package material is Pb-Free Product & RoHS compliant for the purpose of environmental protection and for sustainable development of the Earth.

● Ordering Information

Orderable Part Number	Package	Marking
AM1107	SOP-8	AM1107

● **Absolute Maximum Ratings (T_A=25°C)**

Parameter	Symbol	Limits	Unit
Power Supply voltage	PVCC/VCC	12	V
Output continuous current	I _{ocont}	1.3 (NOTE*)	A
Output peak current	I _{omax}	2.5	A
Operate temperature range	T _{opr}	-20~+85	°C
Storage temperature range	T _{stg}	-40~+150	°C

Note *: Based on 40x40mm² FR4 PCB (1 oz.) at single side PCB

● **Recommended operating conditions (T_A =25°C)**

(Set the power supply voltage taking allowable dissipation into considering)

Parameter	Symbol	Min	Typ	Max	Unit
Power Supply voltage for H-Bridge	PVCC	2.0(Note**)		11	V
IC operating voltage	VCC	2.0(Note**)		11	V
Signal input IN_A and IN_B voltage	V _{IN_x}	-0.3		V _{cc} +0.3	V
H-bridge output continuous current	I _{OUT}	0		1.3(Note*)	A
Externally applied PWM frequency	F _{IN_x}	0.02		65	KHz

Note* : Based on 40x40mm² FR4 PCB (1 oz.) at single side PCB

Note** : The VCC/PVCC should be considered when using 2.76V LDO.

● **Electrical Characteristics (Unless otherwise specified, TA = 25°C ,PVCC=VCC=6V)**

Parameter	Symbol	Limit			Unit	Conditions
		Min	Typ	Max		
Power Supplies						
Supply current	I _{CC}		35		uA	Input signal IN_A/B= L/H 、 H/L or H/H, No load on OUT_A/B, no load on LDO
Standby current	I _{STB}			20	uA	Input signal IN_A/B= L/L, No load on OUT_A/B, no load on LDO
IN_x Inputs						
Input H level voltage	V _{IN_XH}	2.0		V _{CC}	V	
Input L level voltage	V _{IN_XL}	0		0.7	V	
Input H level current	I _{IN_X}		30		μA	V _{CC} = 6V , V _{IN_X} = 3 V
Input frequency	F _{IN_X}	0.02		65	kHz	
Input pull down resistance	R _{IN_X}		100		kΩ	
H-bridge FETs						
On-resistance	R _{ds(on)}		0.58		Ω	I _O = 0.6A Upper and Lower total
LDO parameter						
LDO output voltage	V _{LDO}	2.54	2.76	2.98	V	I _{LDO} = 100mA
Line regulation	ΔV _{LDO-Line}			50	mV	I _{LDO} = 100mA, V _{CC} = 3.3~11V
Load regulation	ΔV _{LDO-Load}			50	mV	I _{LDO} = 0~100mA
Dropout voltage	ΔV _{Drop}			300	mV	I _{LDO} = 100mA
Power supply rejection ratio	PSRR		45		dB	I _{LDO} = 10mA, f = 120Hz V _{ripple} = 1Vp-p
TSD Protections						
Thermal shutdown protection	TSD _p		150		°C	
Thermal shutdown release	TSD _r		100		°C	

● Block Diagram

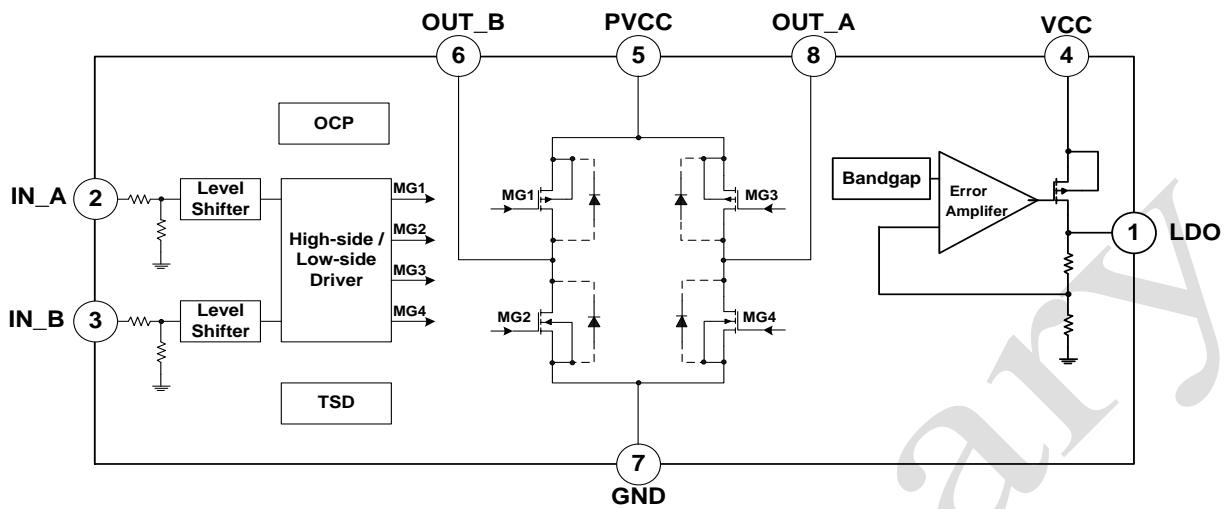

● Input Logic Descriptions

Function truth table

IN_A	IN_B	OUT_A	OUT_B	Mode
L	L	Hi-Z	Hi-Z	Stop
L	H	L	H	Reverse
H	L	H	L	Forward
H	H	L	L	Brake

● Pin configuration SOP-8

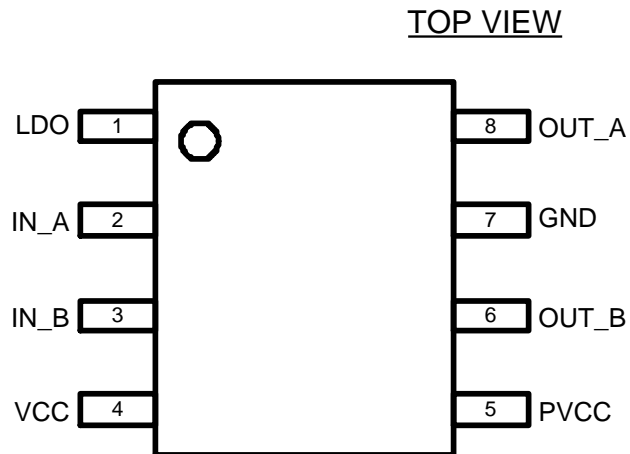

● Pin Descriptions

PIN No.	Pin Name	I/O	Description
1	LDO	O	Low Dropout Regulator
2	IN_A	I	Input Half Bridge A
3	IN_B	I	Input Half Bridge B
4	VCC	-	Power Supply
5	PVCC	-	Power Supply for H-Bridge
6	OUT_B	O	Output Half Bridge B
7	GND	-	Ground Pin
8	OUT_A	O	Output Half Bridge A

● Application

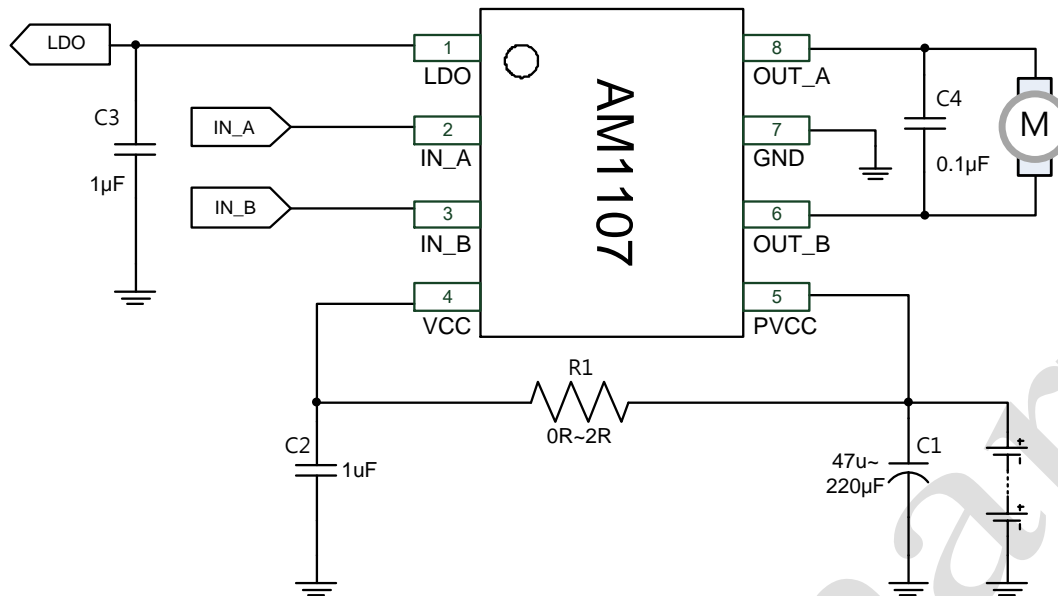

● Circuit Descriptions

The function descriptions of capacitors on the application circuit:

C1 - C2: Power supply PVCC/VCC pin capacitor:

- 1) The capacitor can reduce the power spike when the motor is in motion. To avoid the IC directly damaged by the PVCC/VCC peak voltage. It also can stabilize the power supply voltage and reduce its ripples.
- 2) The C1 capacitor can compensate power when motor starts running.
- 3) The capacitor value (μF) determines the stability of the PVCC/VCC during motor in motion. In general, $47\mu\text{F}$ capacitor is enough in low voltage power (PVCC), $1\mu\text{F}$ capacitor is enough in low voltage power (VCC). If the large voltage power or a heavy loading motor is used, then a larger capacitor would be needed.
- 4) On the PCB configuration, the C1 - C2 must be mounted as close as possible to VCC/PVCC pin (PIN4/PIN5).

C3: The LDO output capacitor

- 1) The capacitor can reduce the power spike while motor is in motion; it also can stabilize the LDO output voltage and reduce its ripples.

C4: The across-output capacitor

- 2) The capacitors can reduce the power spike of motor when operating. Therefore, a $0.1\mu\text{F}$ capacitor is recommended.
- 3) On the PCB configuration, the C4 must be mounted as close as possible to OUT_A&B (PIN 6 & PIN 8).
- 4) The C4 capacitor must be added to the general application.

● Operating Mode Descriptions

1) H-Bridge basic operating mode :

a) Forward mode

Definition : When $IN_A=H$, $IN_B=L$, then $OUT_A=H$, $OUT_B=L$

b) Reverse mode

Definition : When $IN_A=L$, $IN_B=H$, then $OUT_B=H$, $OUT_A=L$

c) Brake mode

Definition : When $IN_A=IN_B=H$, then $OUT_A=OUT_B=L$

d) Stop mode

Definition : When $IN_A=IN_B=L$, then $OUT_A=OUT_B=Hi-Z$

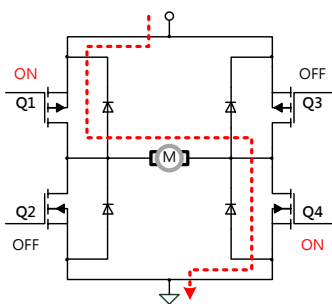

a) Forward mode

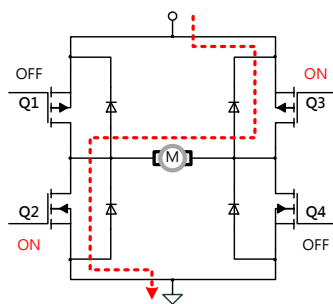

b) Reverse mode

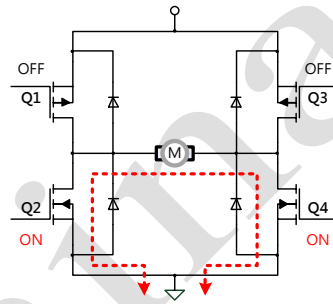

c) Brake mode

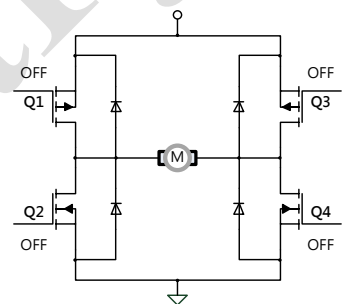

d) Stop mode

● Protection Mechanisms Descriptions

1) Over-temperature protection

If the IC junction temperature exceeds 150 ° C (Typ.), the internal over-temperature protection function will be triggered, all FETs in the H-bridge are disabled, that will ensure the safety of customers' products. If the IC junction temperature falls to 100 ° C(Typ.), the IC resumes automatically.

2) Over-current protection (OCP)

While the IC conducts a large current, 2.5A (Typ), the internal over-current protection function will be triggered. The device enter protection mode of auto-recover to avoid damaging IC and system.

● Thermal Information

θ_{ja}	junction-to-ambient thermal resistance	158.63°C/W
Ψ_{jt}	junction-to-top characterization parameter	5.39°C/W

- **θ_{ja}** is obtained in a simulation on a JEDEC-standard 1s0p board as specified in JESD-51.
- The **θ_{ja}** number listed above gives an estimate of how much temperature rise is expected if the device was mounted on a standard JEDEC board.
- When mounted on the actual PCB, the **θ_{ja}** value of JEDEC board is totally different than the **θ_{ja}** value of actual PCB.
- **Ψ_{jt}** is extracted from the simulation data to obtain **θ_{ja}** using a procedure described in JESD-51, which estimates the junction temperature of a device in an actual PCB.
- The thermal characterization parameter, **Ψ_{jt}**, is proportional to the temperature difference between the top of the package and the junction temperature. Hence, it is useful value for an engineer verifying device temperature in an actual PCB environment as described in JEDEC JESD-51-12.
- When Greek letters are not available, **Ψ_{jt}** is written Psi-jt.
- Definition:

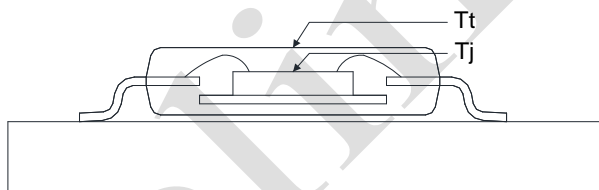

DEFINITION : $\Psi_{jt} = (T_j - T_t) / P_d$

Where :

Ψ_{jt} (Psi-jt) = Junction-to-Top(of the package) °C/W

T_j= Die Junction Temp. °C

T_t= Top of package Temp at center. °C

P_d= Power dissipation. Watts

- Practically, most of the device heat goes into the PCB, there is a very low heat flow through top of the package, So the temperature difference between **T_j** and **T_t** shall be small, that is any error caused by PCB variation is small.
- This constant represents that **Ψ_{jt}** is completely PCB independent and could be used to predict the **T_j** in the environment of the actual PCB if **T_t** is measured properly.

● How to predict T_j in the environment of the actual PCB

Step 1 : Used the simulated Ψ_{jt} value listed above.

Step 2 : Measure **T_t** value by using

➤ Thermocouple Method

We recommend use of a small ~40 gauge(3.15mil diameter) thermocouple. The bead and thermocouples wires should touch the top of the package and be covered with a minimal amount of thermally conductive epoxy. The wires should be heat-insulated to prevent cooling of the bead due to heat loss into wires. This is important towards preventing “too cool” **T_t** measurements, which would lead to the calculated **T_j** also being too cool.

➤ IR Spot Method

An IR Spot method should be utilized only when using a tool with a small enough spot area to acquire the true top center “hot spot”.

Many so-called “small spot size” tools still have a measurement area of 0~100+mils at “zero” distance of the tool from the surface. This spot area is too big for many smaller packages and likely would result in cooler readings than the small thermocouple method. Consequently, to match between spot area and package surface size is important while measuring **T_t** with IR sport method.

Step 3 : calculating power dissipation by

$$P \cong (VCC - |V_{o_Hi} - V_{o_Lo}|) \times I_{out} + VCC \times I_{cc}$$

Step 4 : Estimate **T_j** value by

$$T_j = \Psi_{jt} \times P + T_t$$

Step 5: Calculated **Θ_{ja}** value of actual PCB by the known **T_j**

$$\Theta_{ja}(\text{actual}) = (T_j - T_a) / P$$

- Maximum Power Dissipation (de-rating curve) under JEDEC PCB & actual PCB

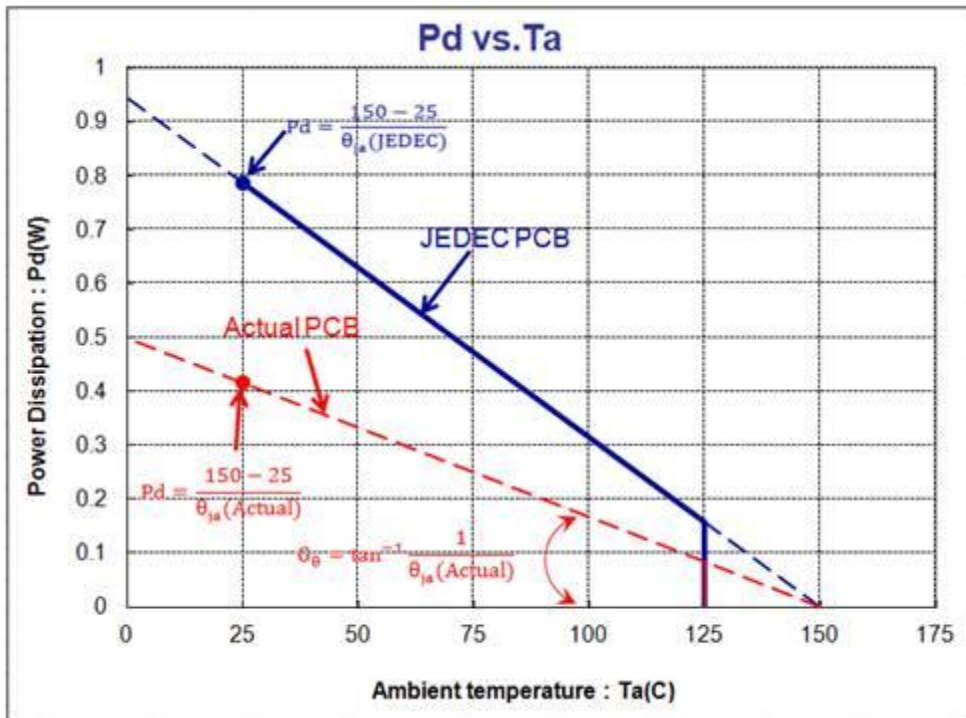

● Packaging outline --- SOP-8

Unit : mm

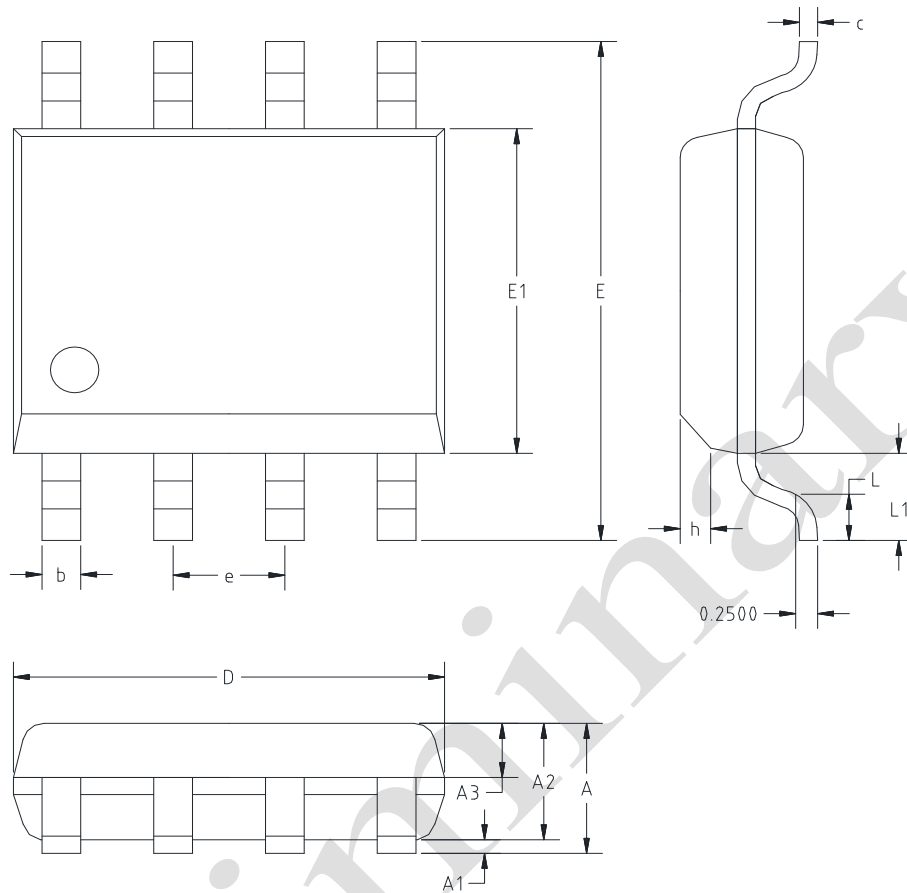

SYMBOL	MILLIMETERS		INCHES	
	Min.	Max.	Min.	Max.
A	--	1.75	--	0.069
A1	0.10	0.225	0.004	0.009
A2	1.30	1.50	0.051	0.059
A3	0.60	0.70	0.024	0.028
b	0.39	0.48	0.015	0.019
c	0.21	0.26	0.008	0.010
D	4.70	5.10	0.185	0.201
E	5.80	6.20	0.228	0.244
E1	3.70	4.10	0.146	0.161
e	1.27 TYP.		0.05 TYP.	
h	0.25	0.50	0.010	0.020
L	0.50	0.80	0.020	0.031
L1	1.05 TYP		0.041 TYP.	

● **Marking Identification**

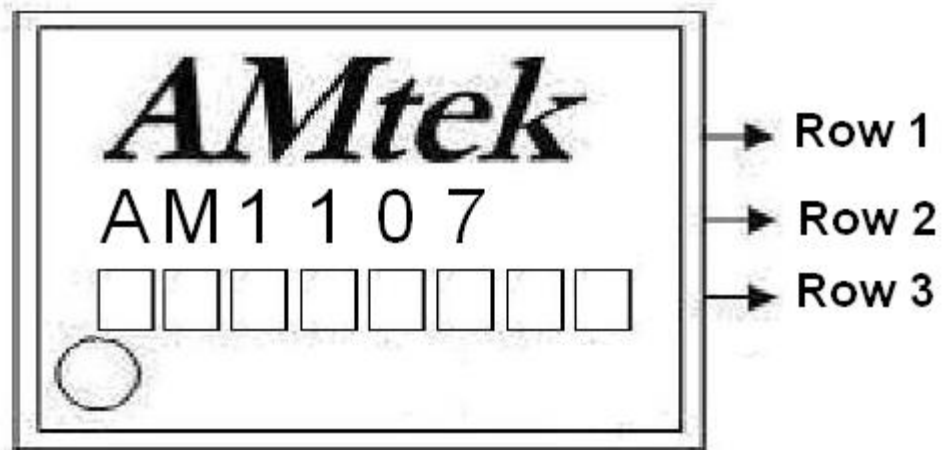

NOTE:

- Row1 : Logo
- Row2 : Device Name
- Row3 : Wafer Lot No · Assembly Year · Assembly Date Code

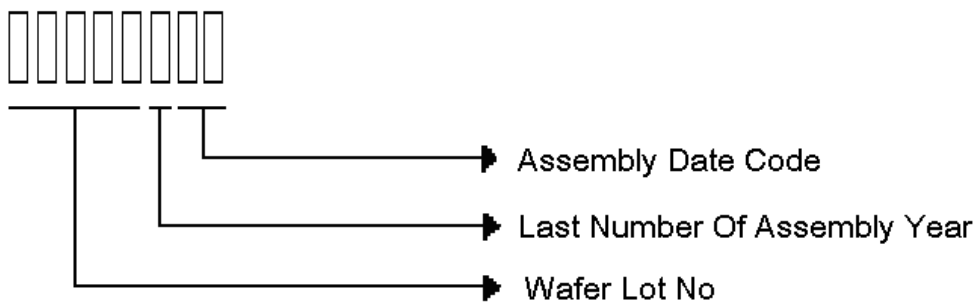

Example: Wafer lot no is GF530 + Year 2016 is G + Week 15 is 15 · we type "GF530G15"

The last code of assembly year, explanation as below: :

(Year : A=0,B=1,C=2,D=3,E=4,F=5,G=6,H=7,I=8,J=9. For example: year 2016=G)