

One Channel H-Bridge Power Driver AM1058A

● Features and Benefits

- Wide supply voltage range up to 11V
- Maximum continuous current output up to 1.1A
- Low standby mode current (<1 μ A)
- Low quiescent operation current
- Low MOSFETs On-resistance 0.55 Ω @I_o=0.6A
- SOP-8 package for small size PCB layout
- Provide four operation modes: forward/reverse/stop/brake
- Over current protection
- Over temperature protection

● Applications

- Toys
- Small Appliances
- RC servo /Robotics
- Consumer Products
- IoT electronic lock

● Description

The AM1058A is one channel H-Bridge driver, It provides integrated motor-driver solution for toys, robotics, consumer products and other low voltage or battery-powered motion control applications. The output driver block consists of N-channel and P-channel power MOSFETs configured as an H-bridge to driver DC motor.

The AM1058A maximum operational voltage is 11V. It can supply up to 1.1 A of output continuous current and 2.5A of output peak current. There are internal shutdown function for over-temperature protection and over-current protection (I_{OC}P = 2.5 A).

Package material is Pb-Free for the purpose of environmental protection and for sustainable development of the Earth.

● Ordering Information

Orderable Part Number	Package	Marking
AM1058A	SOP-8	AM1058A

● **Absolute Maximum Ratings ($T_A = 25^\circ\text{C}$)**

Parameter	Symbol	Limits	Unit
Power Supply voltage	VCC	12	V
Output peak current	I _{omax}	2.5	A
Operate temperature range	T _{opr}	-20~+85	°C
Storage temperature range	T _{stg}	-40~+150	°C

*Based on 25x25 mm² FR4 PCB (1 oz.) at single side PCB

● **Recommended operating conditions ($T_A = 25^\circ\text{C}$)**

(Set the power supply voltage taking allowable dissipation into considering)

Parameter	Symbol	Min	Typ	Max	Unit
Power supply voltage	VCC	2.0		11	V
IN_A and IN_B	V _{IN_X}	-0.3		V _{CC} +0.3	V
H-bridge output continuous current	I _{OUT}	0		1.1*	A
Externally applied PWM frequency	F _{IN_X}	0.02		65	KHZ

*Based on 25x25mm² FR4 PCB (1 oz.) at single side PCB

The output continuous current can be increased when FR4 PCB (1 oz.) size is increased.

● **Electrical Characteristics (Unless otherwise specified, $T_A = 25^\circ\text{C}$, $V_{CC}=6\text{V}$)**

Parameter	Symbol	Limit			Unit	Conditions
		Min	Typ	Max		
Power Supplies						
Quiescent operation current	I_{CC}		35		μA	Input signal IN_A/B= L/H or H/L or H/H, No load on OUT_A/B
Standby mode current	I_{STB}			1	μA	Input signal IN_A/B= L/L, No load on OUT_A/B
PWM inputs						
Input H level voltage	V_{IN_xH}	2.0		V_{CC}	V	
Input L level voltage	V_{IN_xL}	0		0.7	V	
Input H level current	I_{IN_x}		30		μA	$V_{CC} = 6\text{V}$, $V_{IN_x} = 3\text{V}$
Input frequency	F_{IN_x}	0.02		65	kHz	
Input pulldown resistance	R_{IN_x}		100		k Ω	
H-bridge FETs						
On-resistance	$R_{ds(on)}$		0.53		Ω	$I_O = 200\text{mA}$ Upper and Lower total
On-resistance	$R_{ds(on)}$		0.55		Ω	$I_O = 600\text{mA}$ Upper and Lower total
TSD Protections						
Thermal shutdown protection	TSD_p		150		$^\circ\text{C}$	
Thermal shutdown release	TSD_r		100		$^\circ\text{C}$	

● Block Diagram

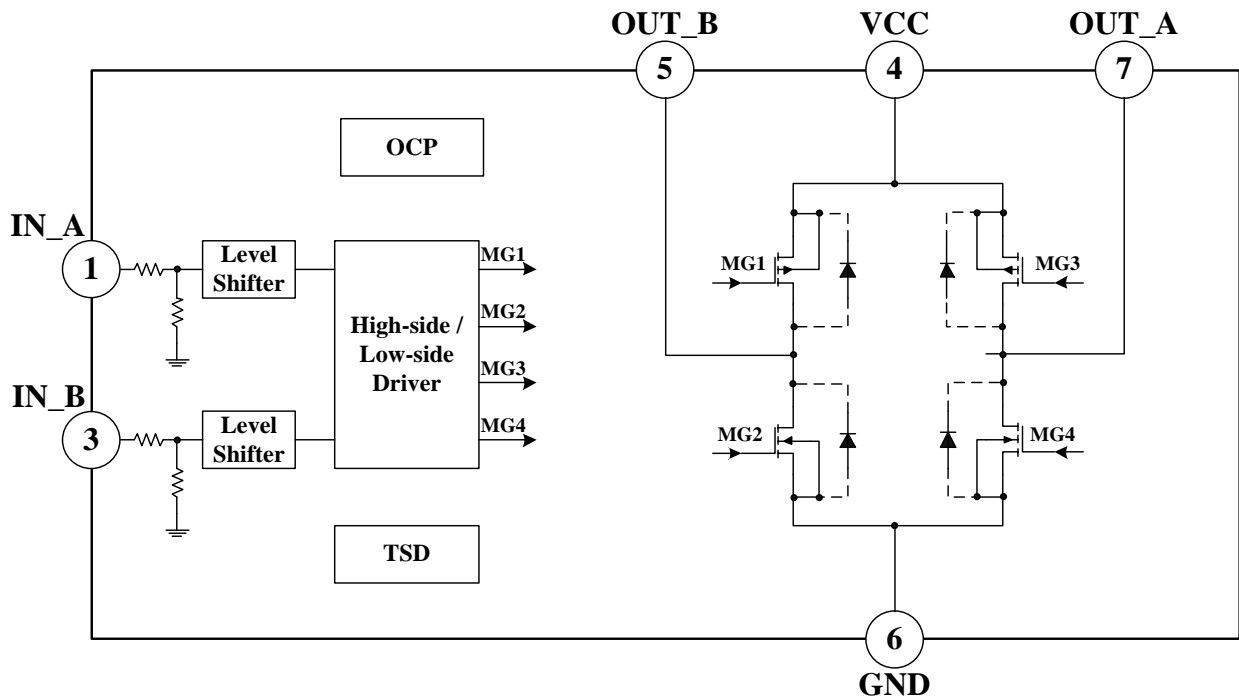

● Input Logic Descriptions

Function truth table

IN_A	IN_B	OUT_A	OUT_B	Mode
L	L	Hi-Z	Hi-Z	Stop
L	H	L	H	Reverse
H	L	H	L	Forward
H	H	L	L	Brake

※Low standby mode current function when IN_A = IN_B = Low level

● Pin configuration SOP-8

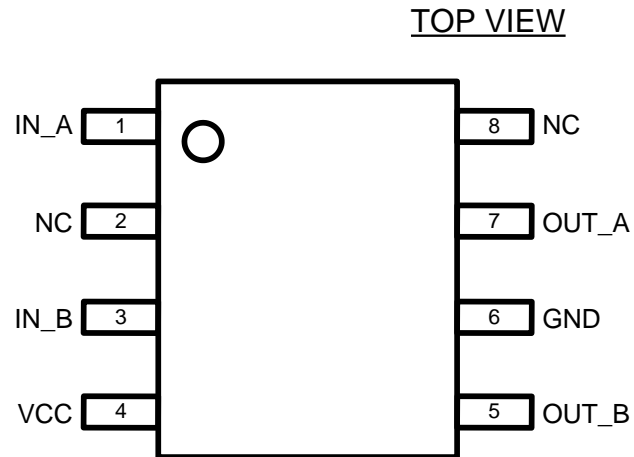

● Pin Descriptions

PIN No	Pin Name	I/O	Description
1	IN_A	I	Input Half Bridge A
2	NC	-	No connector
3	IN_B	I	Input Half Bridge B
4	VCC	-	Power Supply pin
5	OUT_B	O	Output Half Bridge B
6	GND	-	Ground pin
7	OUT_A	O	Output Half Bridge A
8	NC	-	No connector

● Application

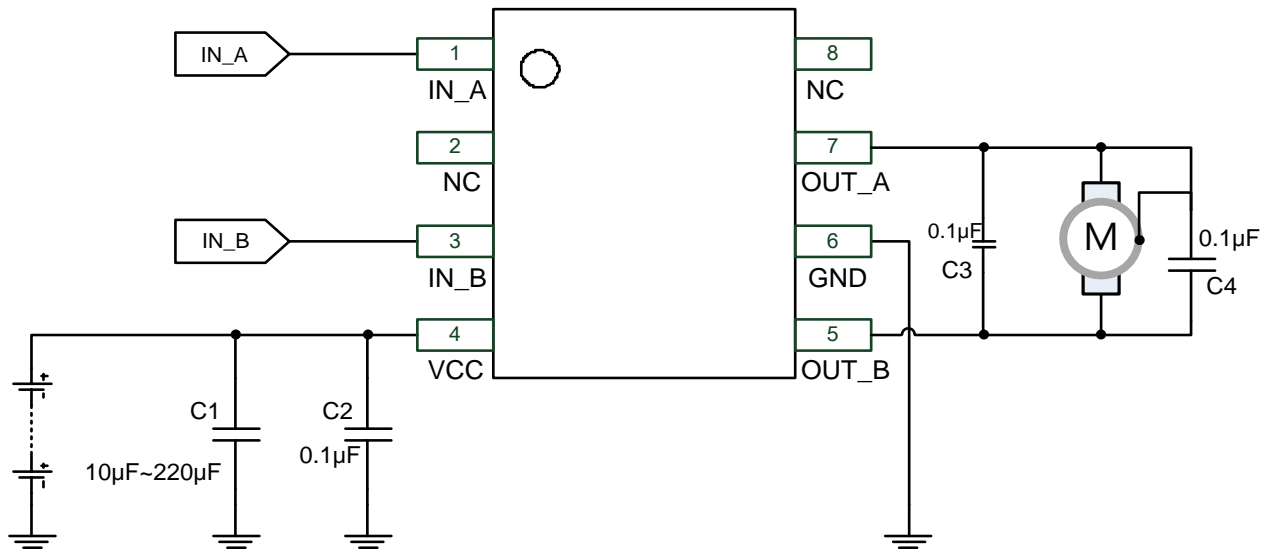

● Circuit Descriptions

The function descriptions of capacitors on the application circuit:

C1 - C2: Power supply VCC pin capacitor:

- 1) The capacitor can reduce the power spike when the motor is in motion. To avoid the IC directly damaged by the VCC peak voltage. It also can stabilize the power supply voltage and reduce its ripples.
- 2) The C1 capacitor can compensate power when motor starts running.
- 3) The capacitor value (μF) determines the stability of the VCC during motor in motion. In general, $10\mu\text{F}$ capacitor is enough in low voltage power (VCC). If the large voltage power or a heavy loading motor is used, then a larger capacitor would be needed.
- 4) On the PCB configuration, the C1 - C2 must be mounted as close as possible to VCC pin (PIN4).

C3: The across-output capacitor ; C4: The across-motor capacitor

- 1) The capacitors can reduce the power spike of motor when operating. Therefore, a $0.1\mu\text{F}$ capacitor is recommended.
- 2) On the PCB configuration, the C3 must be mounted as close as possible to OUT_A&B (PIN 5&PIN 7).
- 3) The C4 capacitor single-ended can be welded on the motor shell.
- 4) The C3 - C4 capacitor must be added to the general application.

● Operating Mode Descriptions

H-Bridge basic operating mode :

- a) Forward mode
Definition : When $IN_A=H$, $IN_B=L$, then $OUT_A=H$, $OUT_B=L$
- b) Reverse mode
Definition : When $IN_A=L$, $IN_B=H$, then $OUT_B=H$, $OUT_A=L$
- c) Brake mode
Definition : When $IN_A=IN_B= H$, then $OUT_A=OUT_B=L$
- d) Stop mode
Definition : When $IN_A=IN_B= L$, then $OUT_A=OUT_B=Hi-Z$

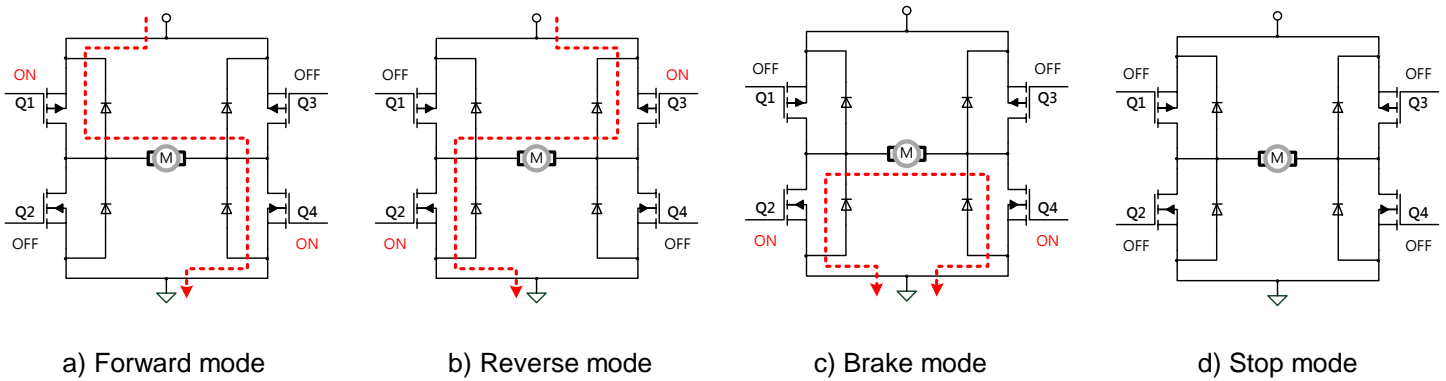

● Protection Mechanisms Descriptions

1) Over-temperature protection
If the IC junction temperature exceeds 150° C (Typ.), the internal over-temperature protection function will be triggered, partial FETs in the H-bridge are disabled, that will ensure the safety of customers' products. If the IC junction temperature falls to 100° C(Typ.), the IC resumes automatically.

2) Over-current protection (OCP)
While the IC conducts a large current, 2.5A (Typ), the internal over-current protection function will be triggered. The device enter protection mode of auto-recover to avoid damaging IC and system.

While the IC output short to ground or output A and B short together, the additional internal protection function will be triggered. The device enter protection mode of auto-recover to avoid damaging IC and system.

● **Thermal Information**

θja	junction-to-ambient thermal resistance	62.5°C/W
Ψjt	junction-to-top characterization parameter	5.8°C/W

- **θja** is obtained in a simulation on a JEDEC-standard 1s0p board as specified in JESD-51.
- The **θja** number listed above gives an estimate of how much temperature rise is expected if the device was mounted on a standard JEDEC board.
- When mounted on the actual PCB, the **θja** value of JEDEC board is totally different than the **θja** value of actual PCB.
- **Ψjt** is extracted from the simulation data to obtain **θja** using a procedure described in JESD-51, which estimates the junction temperature of a device in an actual PCB.
- The thermal characterization parameter, **Ψjt**, is proportional to the temperature difference between the top of the package and the junction temperature. Hence, it is useful value for an engineer verifying device temperature in an actual PCB environment as described in JEDEC JESD-51-12.
- When Greek letters are not available, **Ψjt** is written Psi-jt.
- Definition:

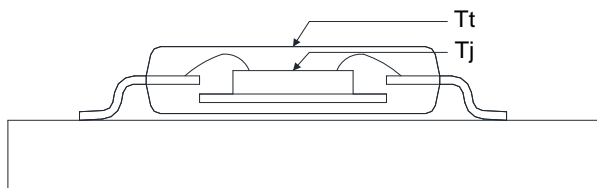

DEFINITION : $\Psi_{jt} = (T_j - T_t) / P_d$

Where :

Ψjt (Psi-jt) = Junction-to-Top(of the package) °C/W

Tj= Die Junction Temp. °C

Tt= Top of package Temp at center. °C

Pd= Power dissipation. Watts

- Practically, most of the device heat goes into the PCB, there is a very low heat flow through top of the package, So the temperature difference between **T_j** and **T_t** shall be small, that is any error caused by PCB variation is small.
- This constant represents that **Ψ_{jt}** is completely PCB independent and could be used to predict the **T_j** in the environment of the actual PCB if **T_t** is measured properly.

● **How to predict T_j in the environment of the actual PCB**

Step 1 : Used the simulated Ψ_{jt} value listed above.

Step 2 : Measure **T_t** value by using

➤ **Thermocouple Method**

We recommend use of a small ~40 gauge(3.15mil diameter) thermocouple. The bead and thermocouples wires should touch the top of the package and be covered with a minimal amount of thermally conductive epoxy. The wires should be heat-insulated to prevent cooling of the bead due to heat loss into wires. This is important towards preventing “too cool” **T_t** measurements, which would lead to the calculated **T_j** also being too cool.

➤ **IR Spot Method**

An IR Spot method should be utilized only when using a tool with a small enough spot area to acquire the true top center “hot spot”.

Many so-called “small spot size” tools still have a measurement area of 0~100+mils at “zero” distance of the tool from the surface. This spot area is too big for many smaller packages and likely would result in cooler readings than the small thermocouple method. Consequently, to match between spot area and package surface size is important while measuring **T_t** with IR sport method.

Step 3 : calculating power dissipation by

$$P \cong (VCC - |V_{o_Hi} - V_{o_Lo}|) \times I_{out} + VCC \times I_{cc}$$

Step 4 : Estimate **T_j** value by

$$T_j = \Psi_{jt} \times P + T_t$$

Step 5: Calculated Θ_{ja} value of actual PCB by the known **T_j**

$$\Theta_{ja}(\text{actual}) = (T_j - T_a) / P$$

● Maximum Power Dissipation (de-rating curve) under JEDEC PCB & actual PCB

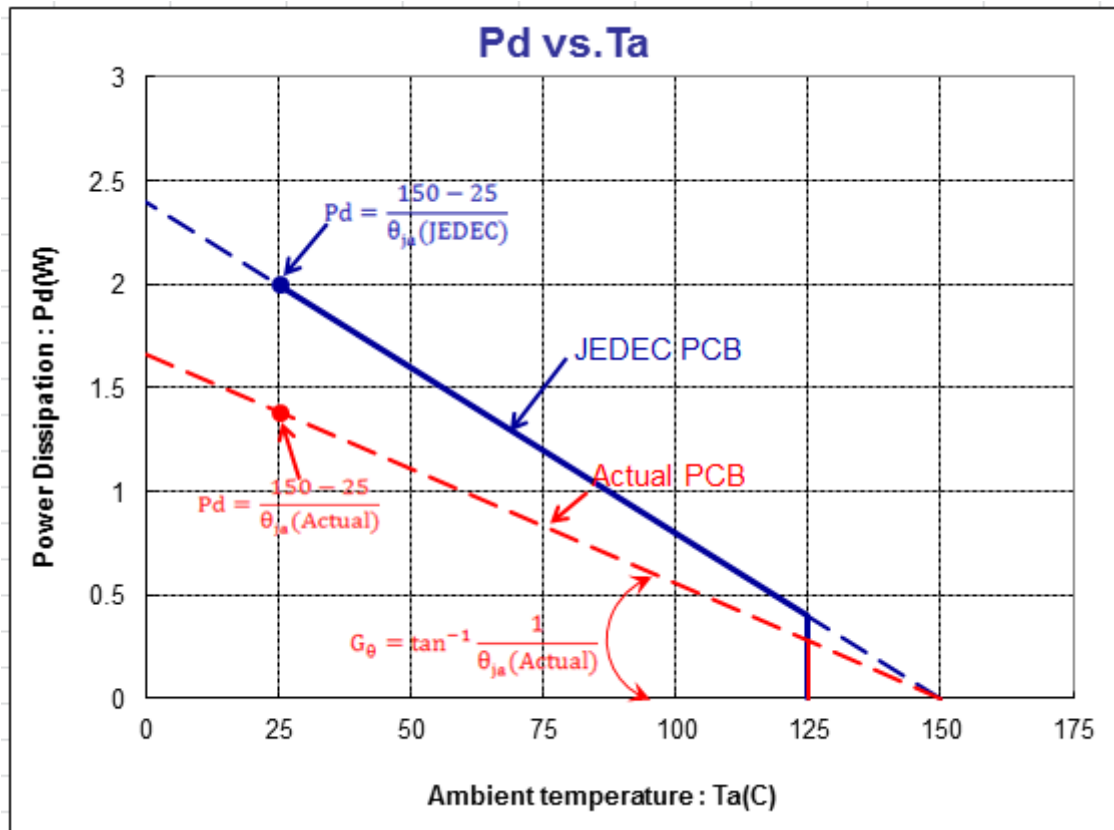

● Packaging outline --- SOP-8

Unit : mm

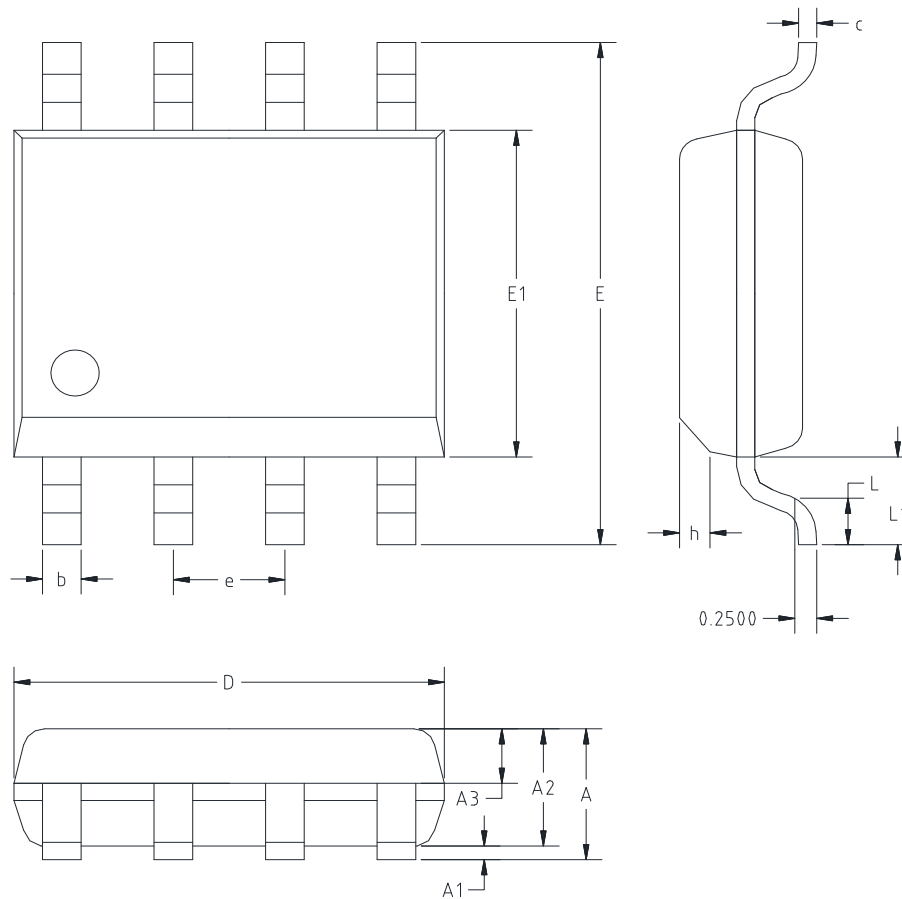

SYMBOL	MILLIMETERS		INCHES	
	Min.	Max.	Min.	Max.
A	--	1.75	--	0.069
A1	0.10	0.225	0.004	0.009
A2	1.30	1.50	0.051	0.059
A3	0.60	0.70	0.024	0.028
b	0.39	0.48	0.015	0.019
c	0.21	0.26	0.008	0.010
D	4.70	5.10	0.185	0.201
E	5.80	6.20	0.228	0.244
E1	3.70	4.10	0.146	0.161
e	1.27 TYP.		0.05 TYP.	
h	0.25	0.50	0.010	0.020
L	0.50	0.80	0.020	0.031
L1	1.05 TYP		0.041 TYP.	

● **Marking Identification**

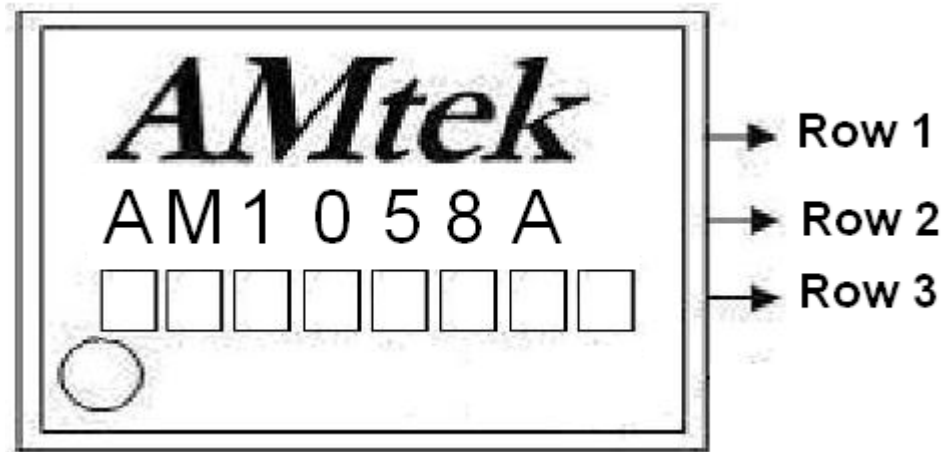

NOTE:

Row1 : Logo

Row2 : Device

Row3 : Wafer Lot No · Assembly Year · Assembly Date Code

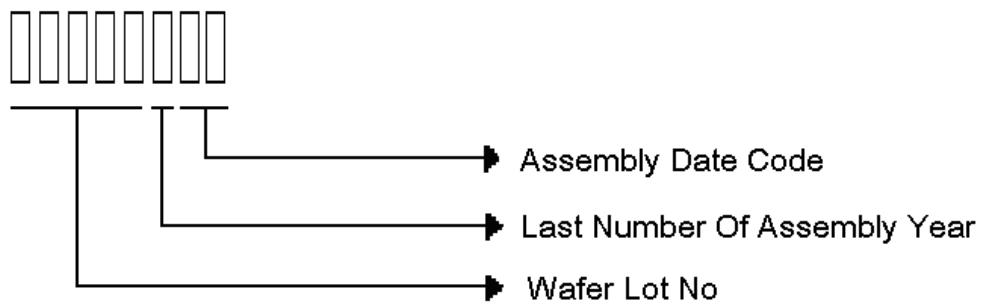

Example : Wafer Lot No is 88888 + last number of assembly year is 5 (F=5) + produce at the week 12

Then mark "88888F12"

Assembly Year Code :

(Year_A=0,B=1,C=2,D=3,E=4,F=5,G=6,H=7,I=8,J=9, e.g. : 2015=F)

Row4 : Product designate code, we type A to discriminate.